





Pyrometer
User Manual

Symbols

The symbols that may be found in this document are defined as follows.

Symbol	Description
 Danger	Indicates a hazardous situation which, if not avoided, will or could result in serious injury.
 Caution	Indicates a potentially hazardous situation which, if not avoided, could result in equipment damage, data loss, performance degradation, or unexpected results.
 Note	Provides additional information to emphasize or supplement important points of the main text.

Safety Instruction

These instructions are intended to ensure that user can use the product correctly to avoid danger or property loss. The device can only be operated by trained personnel in accordance with these instructions and local safety regulations.

Laws and Regulations

- The device should be used in compliance with local laws, electrical safety regulations, and fire prevention regulations.

Transportation

- Keep the device in original or similar packaging while transporting it.
- Do not drop the product or subject it to physical shock. Keep the device away from magnetic interface.

Electrical Safety

- The device external wiring connected to the hazardous live terminals requires installation by an instructed person.
- Make sure that the power has been disconnected before you wire, install, or disassemble the device.
- The device must be connected to an earthed mains socket-outlet.

- Make sure the plug is properly connected to the power socket.
- If the device is powered by terminals connected to the power cord, ensure correct voltage and wiring of the terminals for connection to mains supply.
- DO NOT expose the device to high electromagnetic radiation.

Laser

- Intra-beam viewing of this product is hazardous as laser beam may cause dizziness, flash blindness and visual afterimage. Avoid visual interruption during safety-oriented operations.
- The wavelength is 650~660 nm; the maximum output is 7 mW; laser beam divergence angle is $36 \times 7^\circ$ (maximum: $40 \times 10^\circ$).
- Prevent eyes from direct laser and wear a pair of goggles for your safety. The operating wavelength of the eyewear should be longer than laser peak wavelength and its optical density should be higher than OD5+.
- The following warning labels are attached to the laser aperture of the equipment. An aperture label is affixed close to aperture through which laser radiation is emitted.



- Caution! Use of controls or adjustments or performance of procedures other than those specified herein may result in hazardous radiation exposure.
- The laser radiation emitted from the device can cause eye injuries, burning of skin or inflammable substances. Prevent eyes from direct laser.

Maintenance

- DO NOT maintain the camera when it is powered on, or it may cause electric shock!
- If the product does not work properly, please contact your dealer or the nearest service center. We shall not assume any responsibility for problems caused by unauthorized repair or maintenance.
- Wipe the device gently with a clean cloth and a small quantity of ethanol, if necessary.
- If the equipment is used in a manner not specified by the manufacturer, the protection provided by the device may be impaired.

Contents

1.	Overview.....	1
	1.1 Description	1
	1.2 Dimensions	1
	1.3 Basics	2
	1.3.1 Infrared Radiation and Emissivity.....	2
	1.3.2 1-Color and 2-Color Mode.....	2
	1.3.3 Targets Smaller Than Field of View	3
2.	Appearance.....	4
	2.1 Component.....	4
	2.2 Cable.....	4
3.	Installation	6
	3.1 Positioning	6
	3.1.1 Environment	6
	3.1.2 Distance to Object	7
	3.1.3 Viewing Angles	8
	3.2 Electrical Connection	9
	3.3 Aiming and Focusing.....	10
	3.3.1 Aiming.....	10
	3.3.2 Focusing	11
	3.4 Mechanical Accessories	11
	3.4.1 Fixed Bracket.....	12
	3.4.2 Adjustable Bracket	12
	3.4.3 Air Purge.....	14
	3.4.4 Water/Air Cooled Housing	15
	3.5 Computer Connection	16
	3.5.1 Connect via Network Cable.....	17
	3.5.2 Connect via RS-485 Serial Port.....	18
4.	Device Operation	19
	4.1 Control Interface.....	19
	4.1.1 Visible Light Interface	19
	4.1.2 Temperature Display Interface	20

4.1.3 Operation	22
4.2 Menu Structure	23
4.3 Set Thermometry Parameters	23
4.3.1 Set Thermometry Mode	23
4.3.2 Set Emissivity (1-Color)	24
4.3.3 Set Slope (2-Color).....	25
4.3.4 Set Unit	26
4.4 Set Time Function.....	26
4.4.1 Set Output Time	26
4.4.2 Set Averaging	26
4.4.3 Set Temperature Filter.....	27
4.4.4 Set Peak/Valley Hold	28
4.4.5 Set Oxide Scale Filter.....	28
4.5 Set Alarm.....	29
4.6 Set Analog Output	30
4.7 Set Focus.....	30
4.8 Set Network.....	31
4.9 Set RS-485.....	32
4.10 Set Laser	33
4.11 Set Screen Off.....	33
4.12 Set Advanced Settings	34
4.12.1 Set Attenuation Filter.....	34
4.12.2 Set Lens Smudge Alarm	35
4.12.3 Set Digital Zoom	35
4.12.4 Set Device Initialization.....	35
4.13 View Device Information.....	36
5. Client Operation	37
5.1 Network Connection.....	37
5.1.1 Connect Cable.....	38
5.1.2 Activate Device	38
5.1.3 Add Device	39
5.1.4 Live View	40
5.1.5 Set Thermometry Parameters	41

5.2 Serial Connection.....	41
5.2.1 Connect Cable.....	41
5.2.2 Set RS-485 Parameters	42
5.2.3 Add Device	42
5.2.4 Live View	43
5.2.5 Set Thermometry Parameters	43
5.3 More Frequently Used Features	44
5.3.1 Video and Picture	44
5.3.2 Searching History Temperature.....	44
6. Troubleshooting	46

1. Overview

1.1 Description

The 2-color pyrometer (hereinafter referred to as pyrometer or device) is an intelligent 2-color temperature measuring instrument, which can measure the target of medium and high temperature with high accuracy. The device is often used in various kinds of industrial sites with high demand for temperature control.

Pyrometer determines the temperature by measuring the energy ratio of two close and partially overlapped infrared bands. It can meet the requirements for precise temperature measurement under unstable target conditions (changing emissivity and target size) in complex environments, such as high humidity and dusty environment.

Pyrometer can be applied in medium and high temperature measurement scenarios, such as wire rod, hot rolled sheet, cement kilns, heat treatment, inductive heating, monocrystalline and polycrystalline silicon, etc. It can also be used in super high temperature measurement of vacuum furnace, graphite furnace, high temperature furnace and so on.

1.2 Dimensions

The following figure describes the dimensions of the device.



Note

For detailed technical data, please refer to the technical specifications of the product.

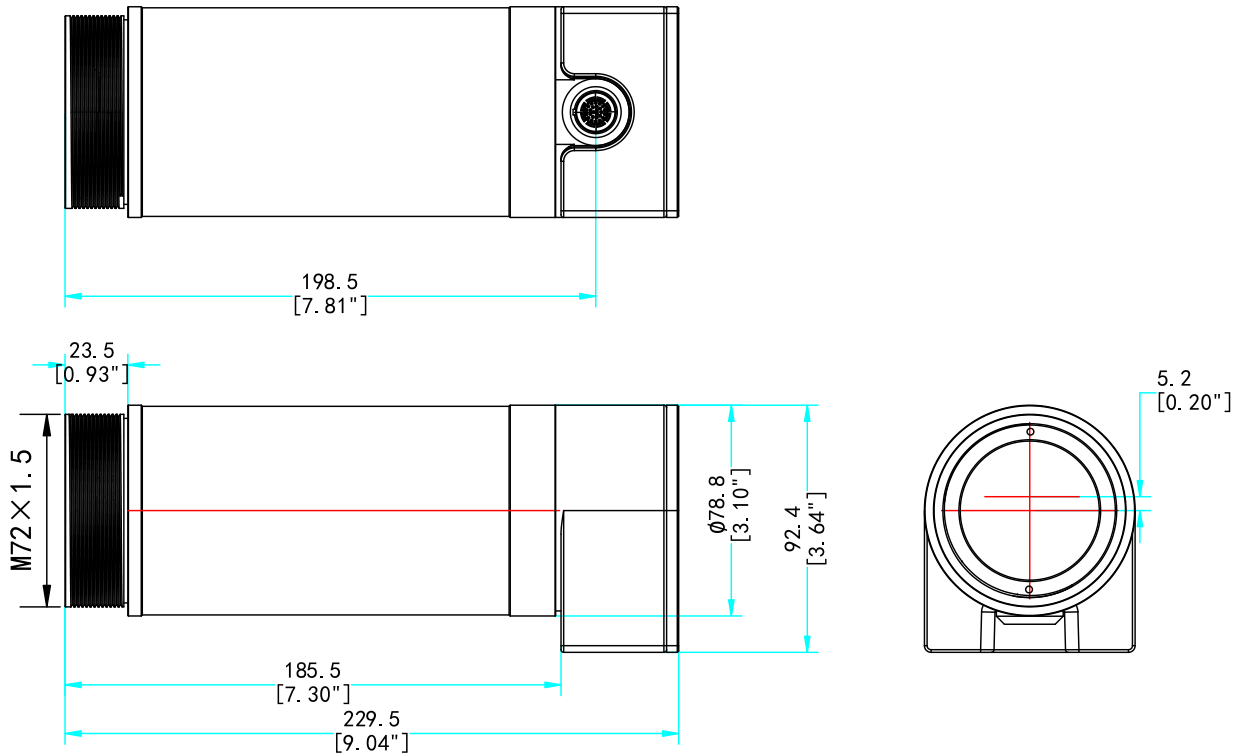

Figure 1-1 Dimensions (Unit: mm [inch])

1.3 Basics

1.3.1 Infrared Radiation and Emissivity

The surface of an object emits infrared radiation, the intensity of which varies with the temperature of the object.

At the same time, according to the material and surface properties, the emitted radiation is roughly in the wavelength range of 1 to 20 μm . This fixed constant, which depends on the substance, is called emissivity. The emissivity of an object depends on the state of the object's surface, for example, the roughness, color, material type, etc. The amount of radiated energy emitted by an object is affected by the emissivity. The higher the emissivity, the greater the infrared radiated energy emitted by the object.

1.3.2 1-Color and 2-Color Mode

The pyrometer supports 1-color and 2-color temperature modes.

The 1-color mode determines the temperature by the radiation energy of a narrow wavelength range emitted from an object. The pyrometer measures the average temperature for a small detection area. Thus, the accuracy of measurement is affected by several factors, such as whether the target emissivity is stable, the

measurement setting-up and the target is correctly arranged, and other environmental factors like background radiation. With proper installation and accessories to prevent the interference from the lens, the influence of external factors to the accuracy could be reduced.

The 2-color mode determines the temperature by the energy ratio of two wavelength bands. This mode is less affected by the changing conditions of the target and the environment. Because the detected energy on both wavelength bands decrease simultaneously, which does not affect to the energy ratio.

1.3.3 Targets Smaller Than Field of View

When the target size is smaller than the field of view of the pyrometer, or the target moves within the field of view, such as narrow cable rods or melted glass, the infrared radiation energy will be reduced. At this point, the 1-color mode cannot obtain the true target temperature. However, since the energy ratio is unaffected, the temperature readings in the 2-color mode remain accurate.



Note

The relationship between the target size and the field of view of the device can affect the actual measurement distance in 1-color mode.

2. Appearance

2.1 Component

The pyrometer appearance is shown in the figure below.

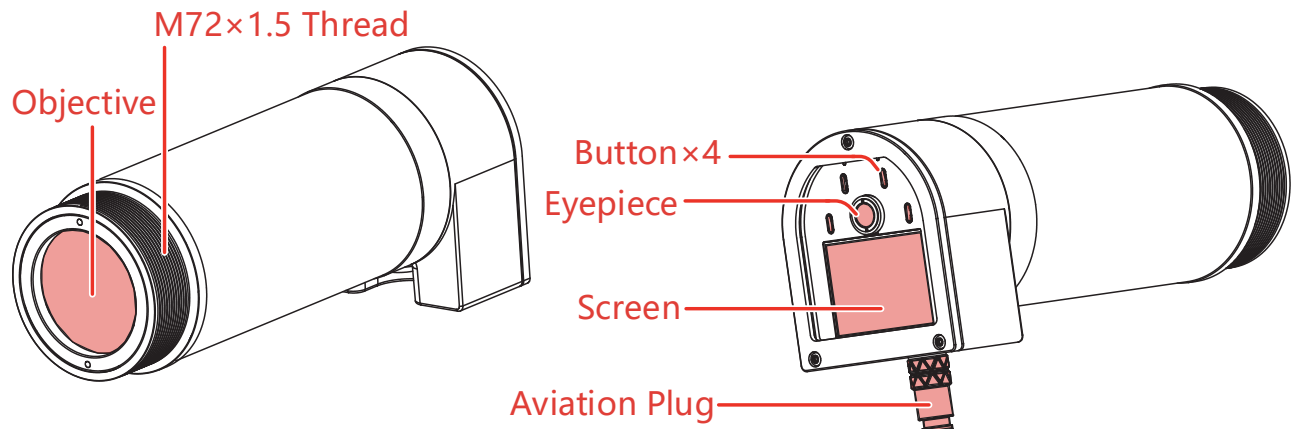

Figure 2-1 Pyrometer Exterior Components

2.2 Cable

The pyrometer comes with 1 standard cable from the factory, one end of which connects to the device's aviation plug, while the other end can be customized for power connection, temperature and alarm signal transmission, etc.

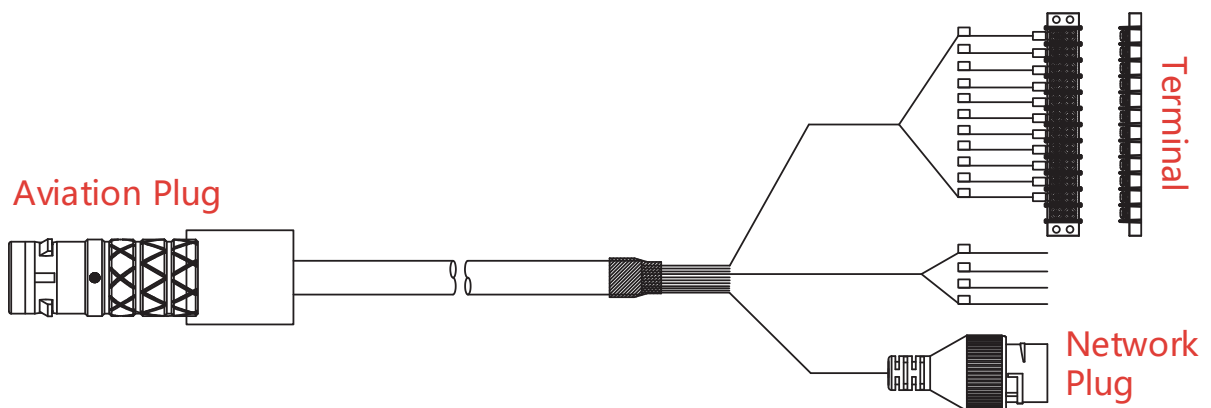

Figure 2-2 Standard Cable

Aviation Plug

Connects to the aviation plug of the pyrometer.

Network Plug

Connects to a switch or router for power and network supply. PoE powered, DC24 V.

Terminal

Table 2-1 Description of the Terminal Wiring Sequence

Wire Number	1	2	3	4	5	6	7	8	9	10	11
Specification	DC 24 V.	Power ground	Analog	Analog output ground	4~20 mA	RS-485+	RS-485-	COM	No.	PNP	GND
Function	Power input		Analog output			RS-485 communication		Alarm output		PNP	

- 1&2: connects to power supply for the device, DC24 V.
- 3&4&5: two analog outputs.
 - 4&3 are selectable analog outputs: 4 mA~20 mA, 0 mA~20 mA, 0 V~5 V, 0 V~10 V; resolution: 16 bit, accurate to 0.1°C; maximum load for current loop output: 600 Ω.
 - 4&5 are fixed analog outputs: 4 mA~20 mA; resolution: 16 bit, accurate to 0.1°C; maximum load for current loop output: 600 Ω.
- 6&7: RS-485 output, half-duplex, capable of long-range signal transmission.
- 8&9: alarm output, optocoupler relay, response time<2 ms.
- 10&11: PNP level output, DC24 V.

3. Installation

3.1 Positioning

3.1.1 Environment

Before determining the installation location of the device, it is necessary to clarify the ambient temperature, air quality, and electromagnetic interference at the site.



Note

For detailed technical data, please refer to the technical specifications of the product.

Ambient Temperature

Under no circumstances should the ambient temperature exceed the maximum allowable operating temperature of the device. Optional water/air cooled housing can reduce internal temperature and increase device adaptability.

Air Quality

If the lens is contaminated or obscured, the measurement accuracy of the pyrometer will also be affected, so the pyrometer should be kept as far as possible away from the heat source. Direct installation in scenarios such as water vapor and mist should be avoided. If necessary, install an air purge or a water/air cooled housing to remove possible contamination.

Electromagnetic Interference

The pyrometer should be installed as far away as possible from potential sources of electromagnetic interference, such as various motor equipment. The following measures are recommended to reduce electromagnetic interference:

- All I/O connections use shielded wiring. For all external wiring, use cable sleeves for protection. Solid tubes are superior to hoses in noisy environment.
- To avoid ground loops, make sure that the device or the external power supply terminal connected to the device is grounded at a single point.



Note

If you are unsure about the temperature measurement mode to use, it is recommended to select installation points that meet the requirements for both 1-color and 2-color modes. Refer to 4.3.1 Set Thermometry Mode.

3.1.2 Distance to Object

The distance to the object is equal to the linear distance from the device lens to the surface of the target being measured.

The actual distance may vary depending on device models. At the same time, due to the different principles of the 1-color and 2-color mode, the requirements for the state of the target, as well as the distance to the object, are all different between two modes.

1-Color mode

In 1-color mode, the focal length of the device lens and the required target size determine the optimal distance to the object. In order to obtain accurate readings, the actual measurement distance needs to meet the following requirements: device minimum focus distance \leq actual measurement distance \leq maximum measurement distance \leq maximum focus distance.

1. Refer to the specifications of the device for the minimum focus distance.
2. Calculate the maximum measurement distance based on the device optical resolution and the diameter of the target.

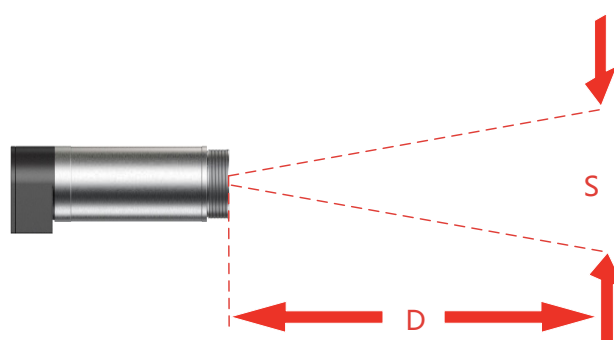

Figure 3-1 Optical Resolution (D:S) as Ratio Between Distance (D) and Spot Size (S)

 **Note**

D represents the distance to object. S represents the diameter of the target spot size. D:S represents the fixed optical resolution. Refer to the technical specifications.

For example: spot size S = 10 mm, device D:S = 100:1, then the maximum measurement distance should be no more than 1000 mm.

3. Adjust the actual distance according to the field of view of the device. The target spot size must completely fill the entire field of view of the device.
- To avoid incorrect readings during actual installation, it is recommended that the installation distance be slightly less than the maximum measurement distance to

ensure that the target can fully cover the field of view, generally 20% greater than the field of view.

- Turn on the laser aiming light and observe the size of the spot and the target. The spot coverage can be considered an area of precise temperature measurement at the current distance.

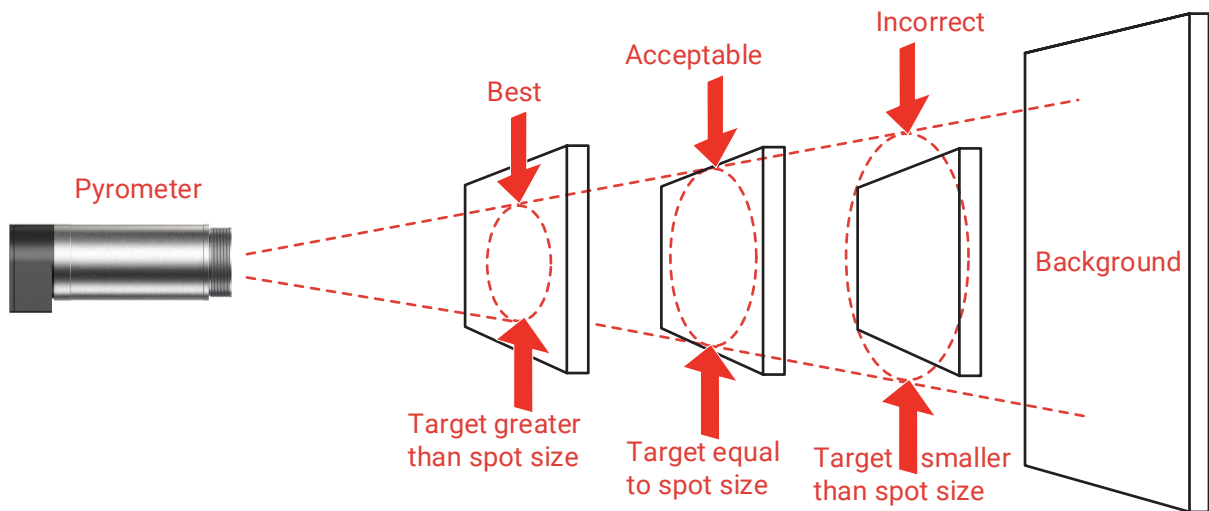

Figure 3-2 Device Placement in 1-Color Mode

2-Color mode

In 2-color mode, the device can be installed at a farther distance, without limitations of the target size and the device's field of view. Please select the actual measurement distance based on the device's focal distance, and refer to the technical specifications of the device to acquire device focal distance.

Note

The accuracy of the temperature reading will still be affected when the device receives a signal that is attenuated below the preset threshold. Refer to 4.12.1 Set Attenuation Filter for attenuation threshold settings.

3.1.3 Viewing Angles

In 1-color mode, it is best for the measurement direction to be perpendicular to the target, with an allowable angle between the measurement direction and the target ranging from 30 degrees to 90 degrees.

In 2-color mode, it is best for the measurement direction to be perpendicular to the target, with an allowable angle between the measurement direction and the target ranging from 45 degrees to 90 degrees.

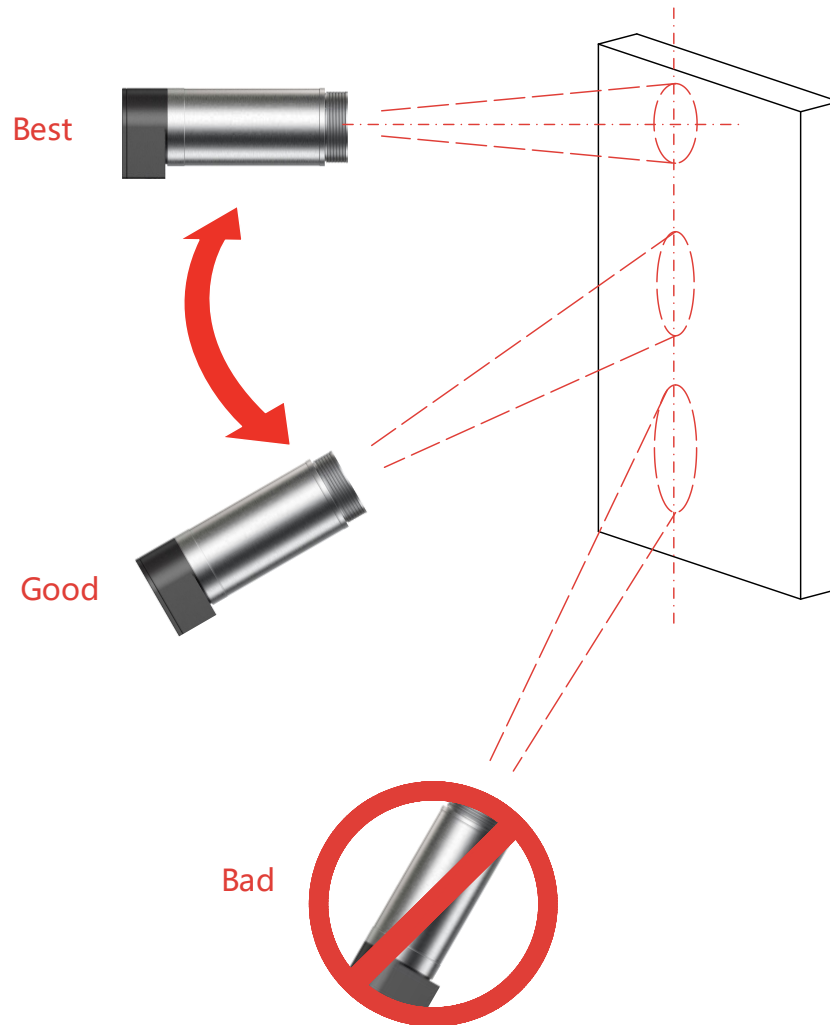

Figure 3-3 Acceptable Viewing Angles

3.2 Electrical Connection

Connect the electrical connections according to the required functions. Use shielded cables for the connections, and configure a voltage converter for devices powered by AC. When the device is used in environments with severe power interference, such as medium frequency furnaces, high frequency furnaces, and induction heating, avoid mixing the device's power supply with the power supply for driving. Make sure to use a clean power supply.

- Choice 1: Use the standard cable, connect one end to the device's aviation plug, and connect the terminal to the external power supply. For wiring sequence instructions, please refer to 2.2 Cable.
- Choice 2: Use the standard cable, connect one end to the device's aviation plug, and connect the network plug to a router or switch to provide PoE power. Refer to 3.5.1 Connect via Network Cable.

3.3 Aiming and Focusing

Out-of-focus or misaligned targeting can affect the accuracy of temperature measurements. Before operation, make sure to aim the device at the target area and adjust the focus for clarity.



Note

- Operation needs to be carried out at the actual installation site to ensure that the focus state and parameter settings are consistent with actual situations.
- Before operating, connect the cables and power on the device.
- It is recommended to debug the equipment before installation. Before debugging, remove any accessories (if any), and check the device's lens, screen, and buttons for aiming, focusing, and parameter settings.

3.3.1 Aiming

Visible Sighting

The device screen displays a visible picture, allowing direct observation of the target position.

1. Aim the device at the target and observe the preview on the screen.
2. Move the device till the target is in the green circle (the actual temperature measurement area) in the center of the preview and aim at the target.

Eyepiece Sighting

The device has a circular eyepiece on the control interface that allows you to observe the target.

1. Aim the device at the target and observe the target in the eyepiece.
2. Make sure that the image is centered in the middle of the reticle. When viewing through eyepiece, move the eyes from side to side to make sure the target does not move out of the reticle.

Laser Sighting

The device supports laser sighting. When the laser is turned on, the visible preview is off and you can observe a red laser spot in front of the lens, indicating the target area.

1. Aim the device at the target and observe the laser spot directly.
2. Position the laser light spot just in the center of the target and aim at the target. The spot area in 1-color mode shall meet the measurement requirements. Refer to 3.1.2 Distance to Object.

3.3.2 Focusing

The device supports two ways of focusing: focusing via object distance and semi-auto focusing.

Once the target is targeted in visible sighting, refer to 4.7 Set Focus to focus until the image details are clear.

3.4 Mechanical Accessories

The device has an M72 × 1.5 standard, 23.5 mm long thread on its front end, which can be installed with optional accessories such as the fixed bracket, adjustable bracket, air-purge, and water/air cooled housing.

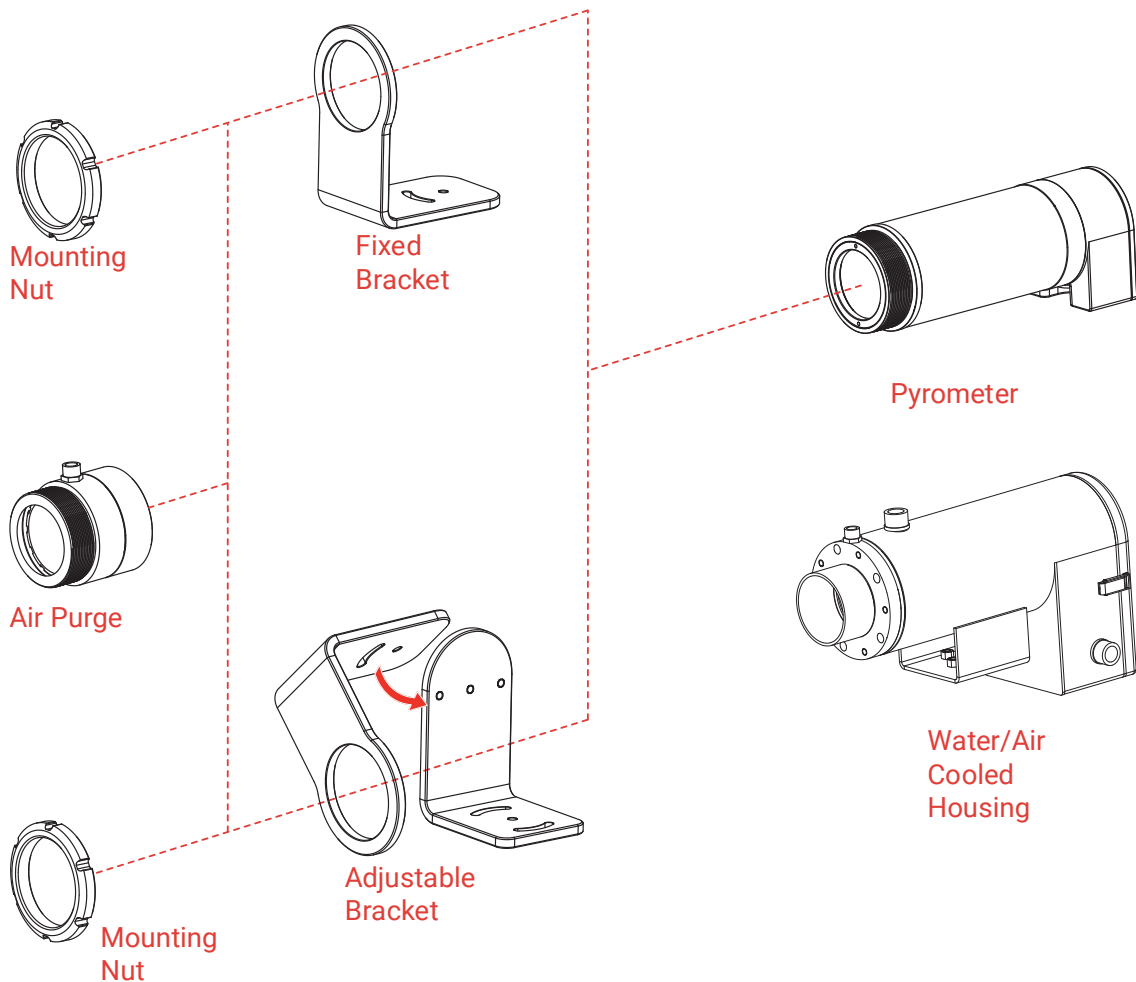

Figure 3-4 Mechanical Accessories

3.4.1 Fixed Bracket

The fixed bracket enables the device to be mounted in a fixed location. For a correct horizontal device orientation, a swivel range within 60° is available.

1. Lock the fixed bracket to the M72 × 1.5 threaded connection on the front of the pyrometer using the mounting nut.
2. The fixed bracket has one 6.5 mm diameter hole and one 6.5 mm wide waist hole at the bottom, which can be mounted with the optional bracket.

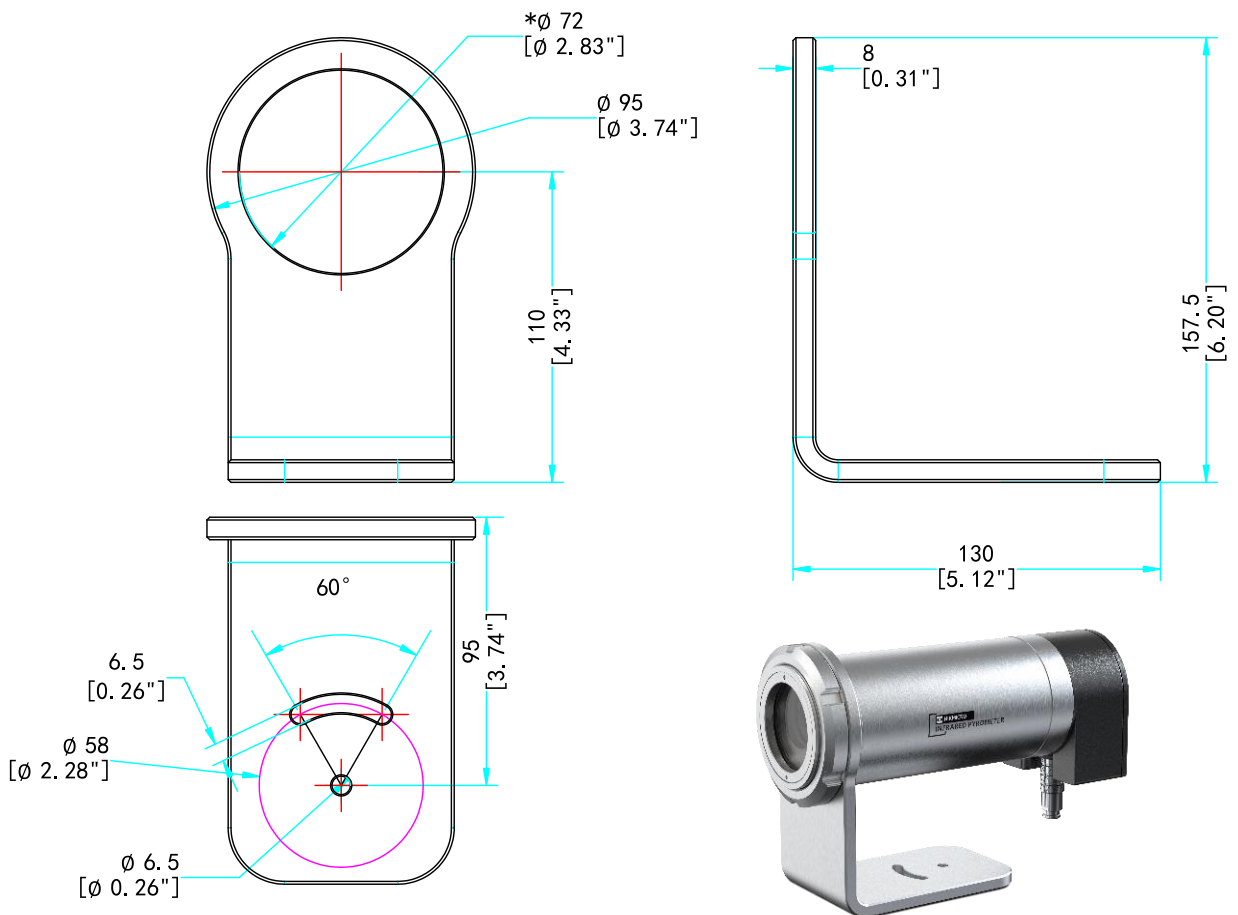

Figure 3-5 Dimension of Fixed Bracket (Unit: mm [inch])

3.4.2 Adjustable Bracket

The adjustable bracket enables the device to be mounted in a movable location. For a correct device orientation, you can pitch and swivel the sighting axis in a range of about 60° per axis.

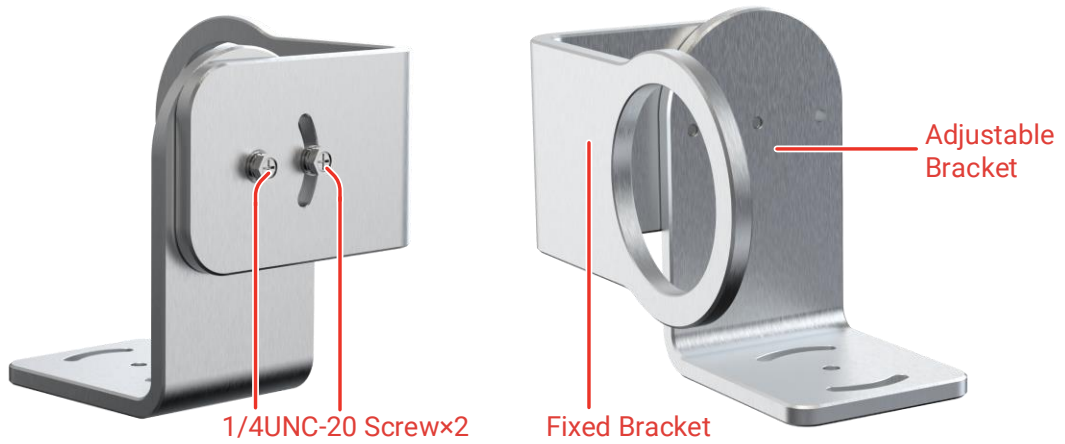

Figure 3-6 Adjustable Bracket

1. Lock the adjustable bracket and fixed bracket using two 1/4UNC-20 screws.
2. Lock the fixed bracket to the M72 × 1.5 threaded connection on the front of the pyrometer using the mounting nut.
3. The adjustable bracket has one 6.5 mm diameter hole and two 6.5 mm wide waist holes at the bottom, which can be mounted with the optional bracket.

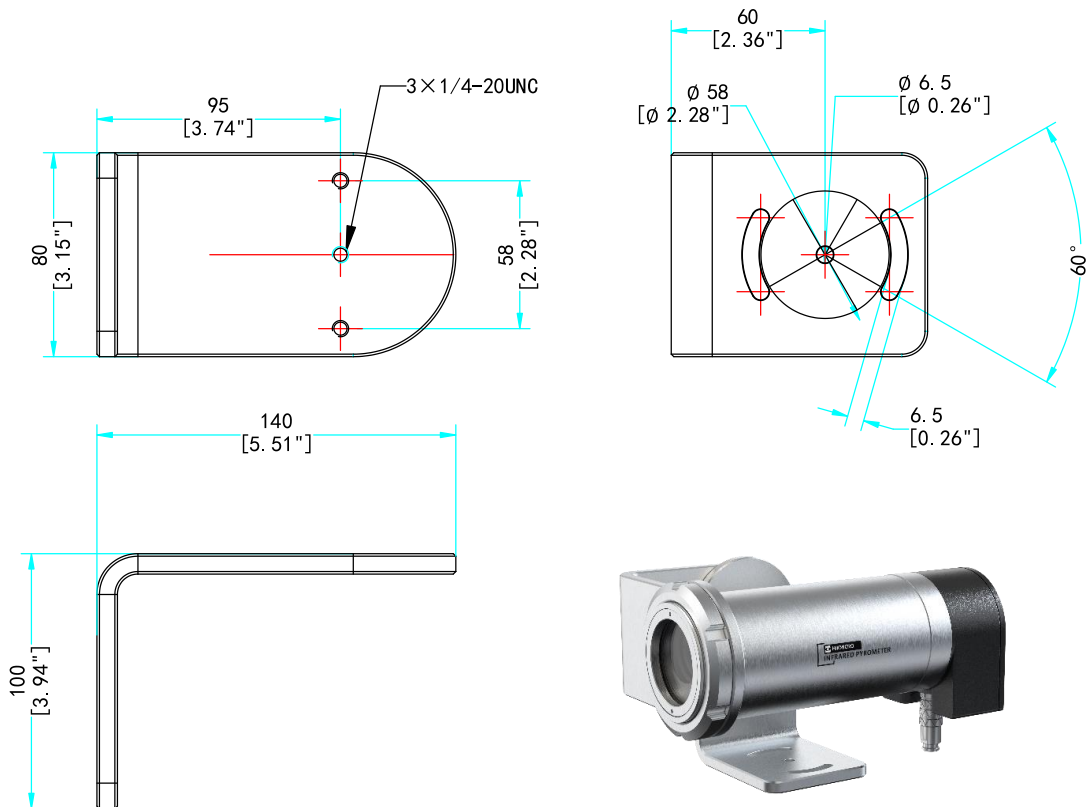

Figure 3-7 Dimension of Adjustable Bracket (Unit: mm [inch])

3.4.3 Air Purge

The air purge is used to remove dust, moisture, water vapor and suspended particles from the pyrometer lens and can be installed with the fixed-bracket.

1. Lock the purge onto the M72 × 1.5 threaded connection on the front of the pyrometer.

 **Note**

The air purge can be used to replace the mounting nut to secure the fixed bracket.

2. Optional bracket can be mounted via the M72 × 1.5 standard, 23.5 mm long threaded connection at the front of the purge.
3. Connect the external purge device via the purge connection (G1/4 pipe thread).

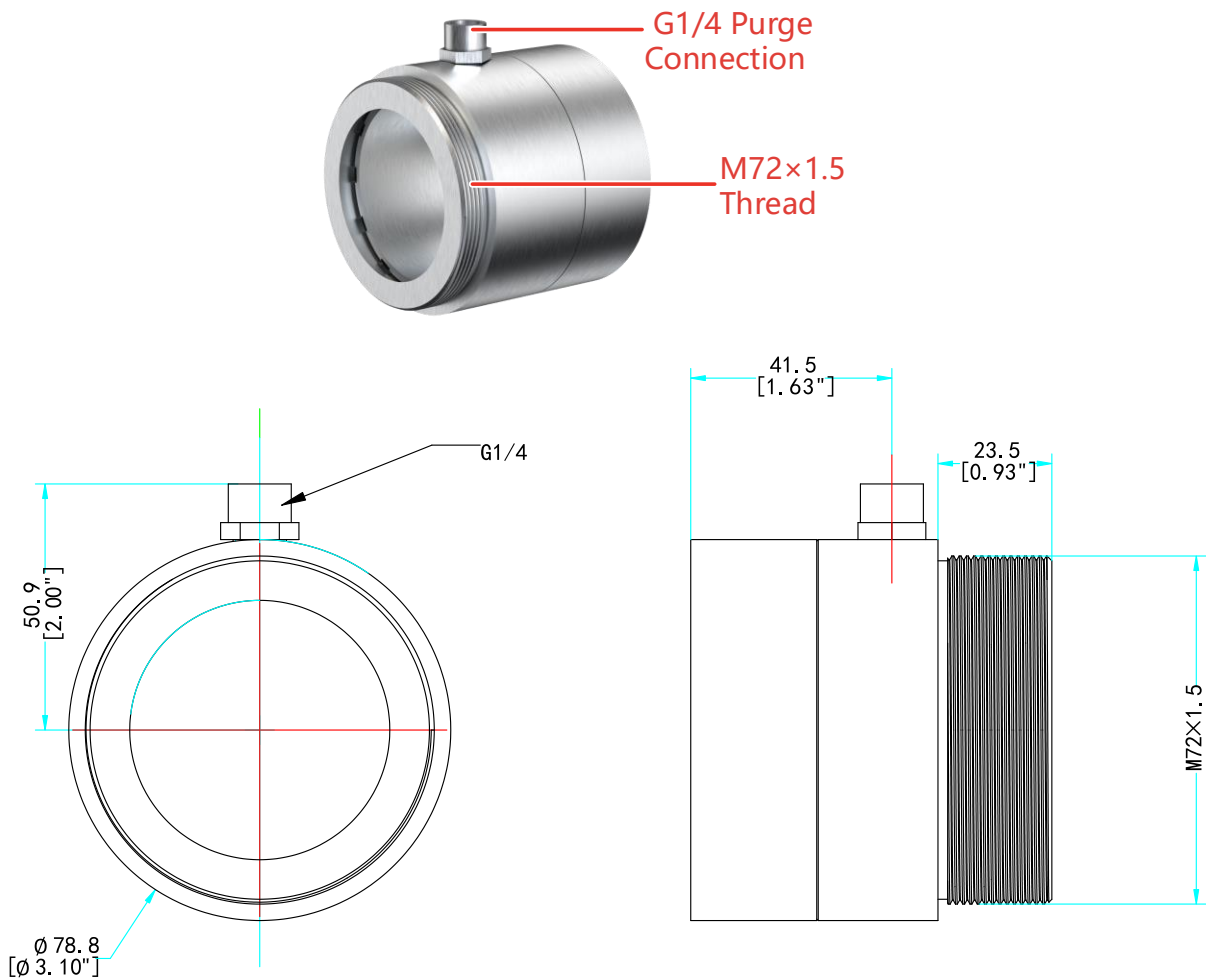

Figure 3-8 Dimension of Air Purge (Unit: mm [inch])



Caution

- When measuring temperature in 1-color mode, the purge must always be supplied with clean and dry compressed air or nitrogen to avoid contaminating the lens area.
 - Do not purge with cold air at temperatures below 10 °C, and the purge input should follow the correct pressure flow.
-

3.4.4 Water/Air Cooled Housing

The water/air cooled housing is used to keep the lens area clean and the interior of the device at a low operating temperature.

1. Remove the rear cover by loosening the two snaps on the two sides of the rear end of the housing.
2. Install the device in position along the inner tube of the housing and secure it with the L-shaped bracket in the inner tube.
3. The housing has four 1/4UNC-20 threaded connections on the bottom bracket, which can be used with DS-1707ZJ-E model bracket for fixed point mounting.

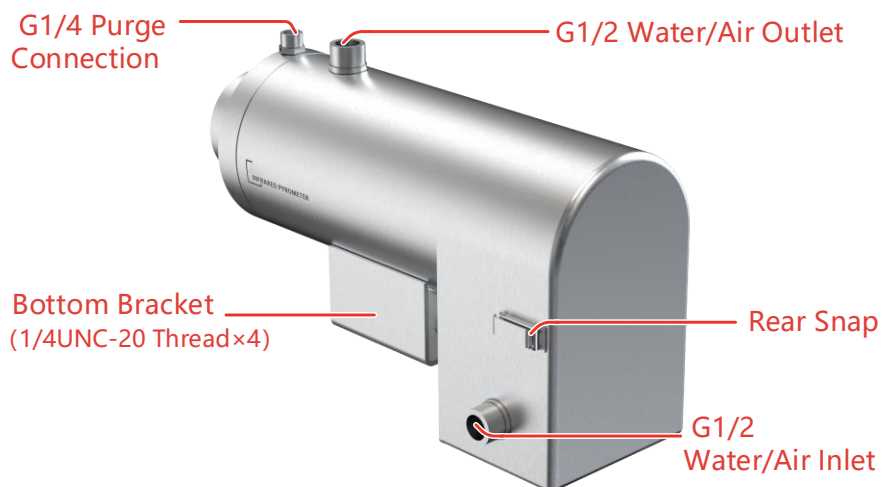

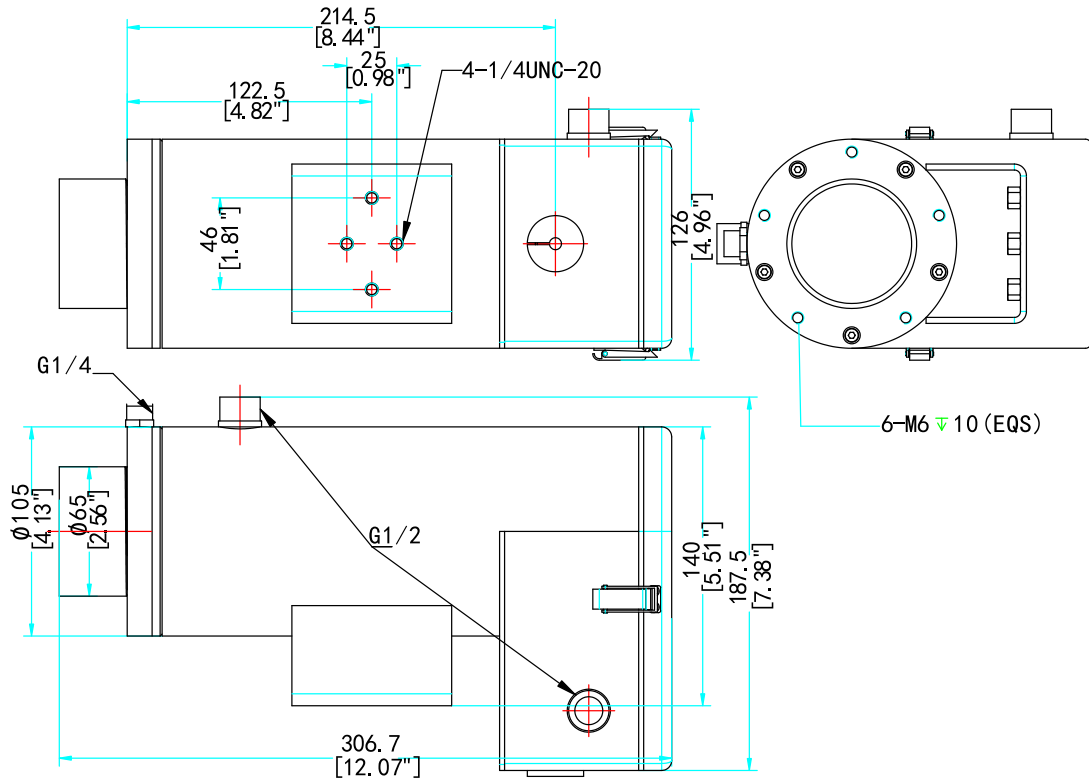

Figure 3-9 Dimension of Water/Air Cooled Housing (Unit: mm [inch])

4. Connect the purge and water/air cooled device via the purge connection, water/air inlet, and water/air outlet. Self-selected connecting hoses, air compressors, and water pumps are available. For situations with higher safety requirements or where water cooling is not suitable, compressed air cooling or vortex coolers can be used for cooling.

⚠ Caution

- When measuring temperature in 1-color mode, the purge must always be supplied with clean and dry compressed air or nitrogen to avoid contaminating the lens area.
- Do not purge with cold air at temperatures below 10 °C, and the purge input should follow the correct pressure flow.

3.5 Computer Connection

For real-time temperature monitoring and remote configuration of the pyrometer via the client, the device and the computer need to be connected to support the implementation via the network or RS-485 serial connection.

3.5.1 Connect via Network Cable

1. Connect the pyrometer and the computer to the same network.

- Choice 1: Connect the device and computer to the switch with a network cable.
- Choice 2: Connect the device to the router or switch first with a network cable, and connect the computer to the same router or switch via Wi-Fi.

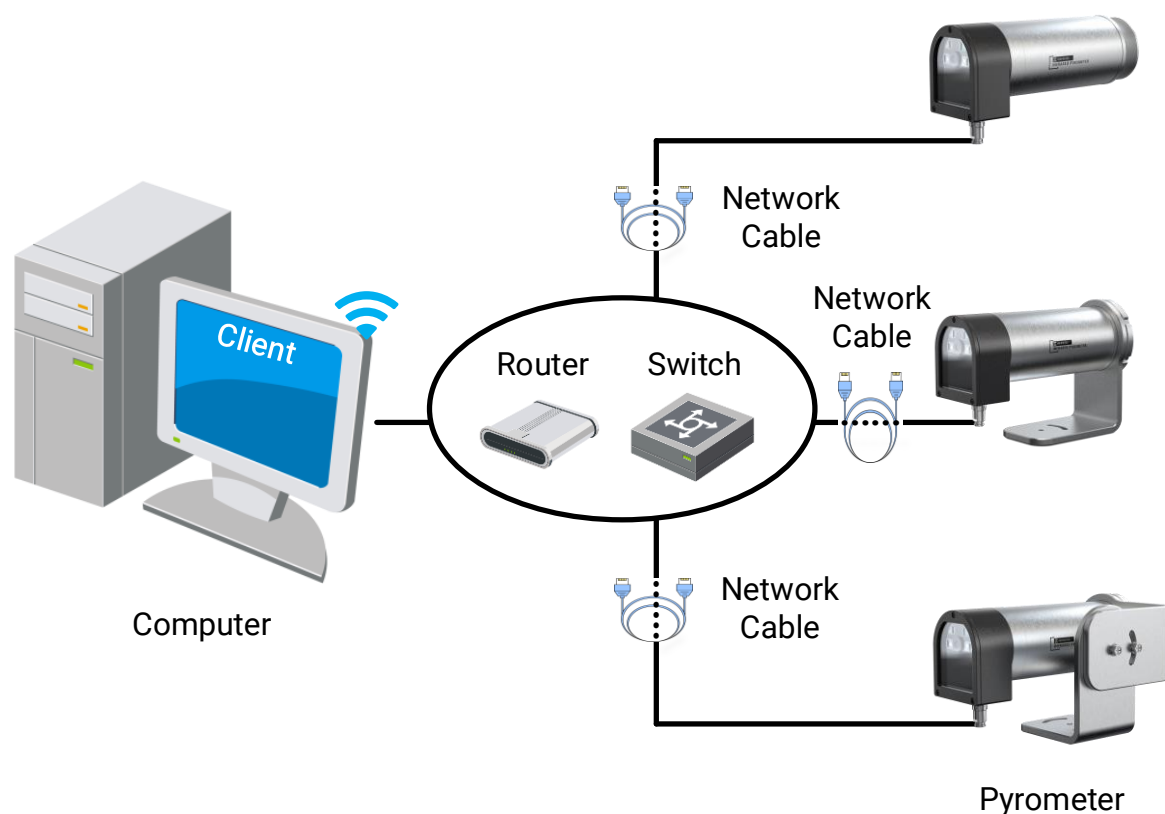

Figure 3-10 Pyrometer Network Connection

2. Set the computer IP address to be on the same network segment as the pyrometer.

Set the IP Address:

Using the Windows 10 operating system of the computer as an example, the steps to set the IP address of the computer are as follows.

Prerequisites: Make sure you have obtained the pyrometer IP address. Refer to 4.8 Set Network . The factory IP address of the device: 192.168.1.64.



Note

Please enter the device IP address in your browser first. If you have normal access to the device, you can skip the following steps.

1. Open your computer's Control Panel and go to **Network and Internet -> Network and Sharing Center**.
2. Select **Ethernet -> Properties**, and double-click **Internet Protocol Version (TCP/IPv4)**.
3. Modify the local computer IP address, subnet mask, and default gateway information. Click **OK**. Make sure both the device and the computer IP address are on the same network segment.

Example: If the device IP address is 192.168.1.64, the computer IP address can be set to any IP address between 192.168.1.2 and 192.168.1.253, except 192.168.1.64.

What to do next: Access the computer client to configure the device. Refer to 5.1 Network Connection for reference.

3.5.2 Connect via RS-485 Serial Port

1. Connect the terminal interface of the device to the USB to RS-485 converter and connect to the computer via USB. Refer to 2.2 Cable for reference.



Note

The USB to RS-485 converter is not included in the package. Please purchase it separately.

2. Set RS-485 parameters for the pyrometer. Refer to 4.9 Set RS-485 for reference.

What to do next: Access the computer client to configure the device. Refer to 5.2 Serial Connection for reference.

4. Device Operation

Once the device is installed and wired, you can configure thermometry parameters at the device end.

This chapter describes how to configure the parameters on the device.

4.1 Control Interface

When the device is powered on, the screen shows the live view as the following figure.

The device supports two modes: visible light live view and temperature display.

You can adjust the settings by key operation. When the settings are adjusted, the display changes accordingly.

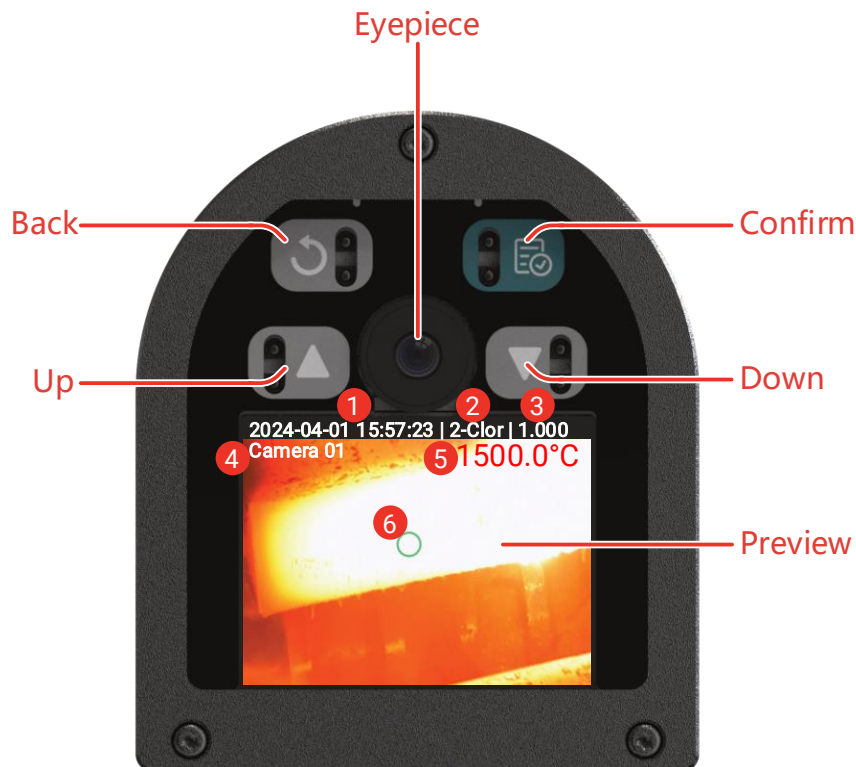

Figure 4-1 Control Interface

4.1.1 Visible Light Interface

The visible light live view interface shows the visible light live view image.

As Figure 4-1 Control Interface shows, the visible light live view interface is displayed after the device is first started.

Table 4-1 Visible Light Live View Interface

No.	Description
1	System time (factory calibrated).
2	Temperature measurement mode, 1-color or 2-color.
3	Emissivity (shown in 1-color) or slope (shown in 2-color).
4	Channel name, which can be modified by web configuration.
5	Temperature value and unit of measured area. Value that is in the normal range is displayed in green, and value that exceeds the alarm threshold is displayed as the upper/lower threshold in red.
6	The actual measured area. The size of the circle is influenced by the optical resolution, and is fixed in the center of the image. The device measures the temperature in the circle area.

4.1.2 Temperature Display Interface

The temperature display interface shows detailed temperature information, time functions, and more.

On the visible light live view page, short press ▲ or ▼ to switch to the temperature display interface, as shown in Figure 4-2 Temperature Display Screen.



Figure 4-2 Temperature Display Screen

Table 4-2 Temperature Display Screen Icons

No.	Description
1	System time (factory calibrated).
2	The device IP address, shown as the default address in the figure.
3	Channel name, which can be modified by web configuration.
4	Temperature value and unit of measured area. Value that is in the normal range is displayed in green, and value that exceeds the alarm threshold is displayed in red. When the measured temperature exceeds the upper/lower temperature range, the temperature range is displayed in red.
5	Device internal temperature value.
6	Thermometry range.
7	Thermometry mode, 1-color or 2-color.
8	Emissivity (shown in 1-color) or slope (shown in 2-color).
9	Special values for time functions. The special values are shown in the following table for all cases.





Table 4-3 Special Value of the Time Function

T	X.	X.	X.	=	X.	ms
Fixed value T.	0: Averaging on 1: Averaging Off	0: Temperature filter on 1: Temperature filter off	0: Peak hold off 1: Peak hold 2: Valley hold	=	Output time	Fixed value, the output time unit
Oxide scale filter on. * Shown only when oxide scale filter is on.						

4.1.3 Operation

Configure the device menu by pressing the buttons.

Table 4-4 Button Description

Button	Description
	The Confirm button. In the live view interface, short press to enter the main menu. At the Menu Setup interface, short press to confirm the current value.
	The Navigate Up button. In the live view interface, short press to switch the display mode. In the Menu Setup interface, short press to move up or adjust the parameters.
	The Navigate Down button. In the live veiw interface, short press to switch the display mode. In the Menu Setup interface, short press to move down or adjust the parameters.
	The Back button. In the live veiw interface, long press to lock/wake the device. * Short press  again to unlock the device after waking it. On the Menu Setup interface, short press to confirm the setting and return to the previous menu.

4.2 Menu Structure

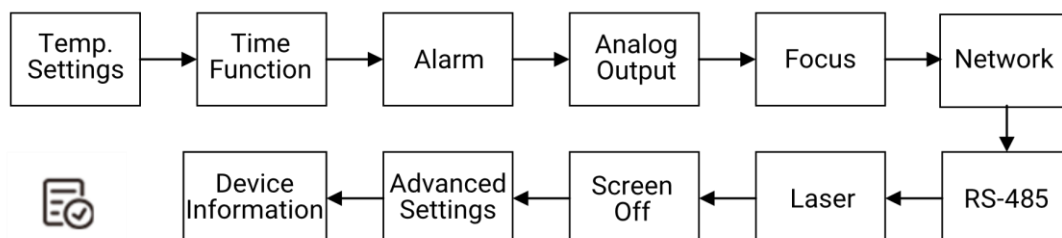

The device main menu is structured as shown below, and you can press  to confirm the selection.



4.3 Set Thermometry Parameters

Set temperature mode and configure the parameter before measurement.

Enter temperature settings menu:

1. At the live view interface, short press  to enter the main menu.
2. Short press ▲ or ▼ to select **Temp. Settings**, and short press  to go to the temperature parameter setup menu.

4.3.1 Set Thermometry Mode





1. In the Temp. Settings menu, short press ▲ or ▼ to select **Mode**.
2. Short press  to switch between **1-Color** and **2-Color**.
3. Short press  to save the settings and return.

Table 4-5 1-Color/2-Color Mode Scenarios

1-Color Mode	2-Color Mode
<ul style="list-style-type: none"> • The background temperature is higher than the target temperature. • Optical channel has little dust and vapor, and is not obstructed. • The surface of the target is flat and the physicochemical state is stable (emissivity is stable). • The target size is larger than the device field of view. 	<ul style="list-style-type: none"> • The working environment has water vapor and dust, and the optical lens is partially blocked, causing energy degradation. • The measured target size and distance will vary. • The target is changed frequently. • The target emissivity is unstable. • Measure small targets at a distance, and the target is smaller than the device field of view.

4.3.2 Set Emissivity (1-Color)

Every object has its emissivity, and the value varies with object surface material ranging from rough to smooth. The emissivity of almost all material in practical applications is less than 1.000. Modify the emissivity of the target on the device to ensure measurement accuracy.

1. Short press ▲ or ▼ to select **Emissivity**.
2. Short press  to confirm.
3. Short press ▲ or ▼ to adjust the value, and short press  to confirm and move to the next position.
4. Short press  to save and return.

 **Note**

In 1-color mode, the target emissivity must be set. For more accurate target emissivity in 1-color mode, refer to the following methods:



- Use a resistance temperature detector (RTD) or thermocouple to detect the real temperature of the target and adjust the emissivity until the device displays the same value as the real temperature of the target.
- If part of the surface of the target is coated with dark black paint, the emissivity in 1-color mode can reach 0.98. Measure the area adjacent to the object and adjust

the emissivity until to the same temperature, which is the correct emissivity for the object.

4.3.3 Set Slope (2-Color)

The emissivity of all real objects changes with wavelength and temperature. The slope is the ratio of the emissivity in two separate wavelength bands. It is to compensate for the difference between the emissivity over two wavelength bands. The factory default values can satisfy most measurements, and adjustments are also supported.

Slope is only supported in 2-color mode, and the default slope factor can be used.

1. Short press ▲ or ▼ to select **Slope**.
2. Short press  to confirm.
3. Short press ▲ or ▼ to adjust the value, and short press  to confirm and move to the next position.
4. Short press  to save and return.

 **Note**

- The following 2-color slope values are approximate values and vary with alloy material and surface finish and application. The data in the table is for reference only.

Table 4-6 Approximate 2-Color Slope for Some Materials



Material	Surface Status	Approximate Slope Factor
Cobalt, Stainless Steel, Nickel, Iron, Steel	Metal oxide surfaces	1.000
Cobalt, Rhodium, Platinum, Iron, Stainless steel, Tungsten, Molybdenum, Steel, Nickel, Tantalum	Smooth, clean, non-oxidized metal finish	1.030
Cast iron	/	1.000

- If you need to obtain an unknown 2-color slope for the target, use a reliable contact thermometer to measure the temperature of the target surface. For example, measure the temperature of several areas on the target and average the

values. Adjust the slope until the temperature measured by the device is equal to the actual temperature of the target.

4.3.4 Set Unit



Set the displayed temperature unit, C for Celsius °C and F for Fahrenheit °F.

1. Short press ▲ or ▼ to select **Unit**.
2. Short press  to switch unit.
3. Short press  to save and return.

4.4 Set Time Function



Set the output time and mode of temperature data. The time function influences the recording and output of temperature data.

Enter the time function menu:

1. In the live view interface, short press  to enter the main menu.
2. Short press ▲ or ▼ to select **Time Function**, and short press  to go to the time function menu.

4.4.1 Set Output Time

Set the output time interval for the measured data, which means that the device performs a temperature recording and output the data at intervals.





1. In the Time Function menu, short press ▲ or ▼ to select **Output Time**.
2. Short press  to go to the setup menu.
3. Short press ▲ or ▼ to adjust the value, and short press  to confirm and move to the next position.
4. Short press  to save and return.

4.4.2 Set Averaging

The measured temperature values are averaged over the specified time interval to obtain a smoother temperature value. For example, if the averaging is set to "3", then the device calculates the average of the measured values over the three output times.





This feature is applicable to temperature measurement scenarios where there are intermittent extremes values. The averaging of temperature values can reduce

temperature fluctuations, improve result stability and is suitable for most applications.

1. In the Time Function menu, short press ▲ or ▼ to select **Averaging**.
2. Short press  to go to the setup menu.
3. Select **Enable** and short press  to turn on the averaging function.
4. Select **Number**, short press  to set the value. Short press ▲ or ▼ to adjust the value, and short press  to confirm and move to the next position.
5. Short press  to save and return.

4.4.3 Set Temperature Filter

Set the temperature range of the measurement and the device will not record the value that is out of the range.



1. In the Time Function menu, short press ▲ or ▼ to select **Temperature Filter**.
2. Short press  to enter the setup menu.
3. Select **Enable** and short press  to turn on the filter.
4. Select **Max. Temp./Min. Temp.** and short press  to set the value. Short press ▲ or ▼ to adjust the value, and short press  to confirm and move to the next position.
5. Select **Mode**, and short press  to switch.

Filter Mode	Description
Reset	When the target temperature is higher than the Max.Temp, the output value is the upper temperature limit (i.e., the Max.Temp). When the target temperature is lower than the Min.Temp, the output value is the lower temperature limit (i.e., the Min.Temp).
Hold	When the target temperature is out of the set temperature range, the output temperature remains at the last measured value that is within the temperature range until a new temperature value within the temperature range is measured.



6. Short press  to save and return.

4.4.4 Set Peak/Valley Hold

The output temperature value only selects the highest or lowest measured temperature. This function is suitable for measuring moving or partially obscured targets (e.g., a mill steel sheet partially covered with scales).

1. In the Time Function menu, short press ▲ or ▼ to select **Peak/Valley Hold**.
2. Short press  to enter the setup menu.
3. Select **Enable** and short press  to turn on the peak/valley hold.
4. Select **Mode** and short press  to switch.

Peak/Valley Hold	Description
Peak Hold	Represents the highest measured temperature value. Peak temperature measurement is suitable for measuring moving targets: When fast moving targets are measured, the passing duration through the detection area is short, e.g., less than 1s, the highest temperature needs to be measured. More accurate measurements can be obtained in this way. Peak Hold can also be used to measure the temperature of metal solutions or liquids.
Valley Hold	Measures the lowest temperature value.

5. Select **Hold Cycle**, and short press  to set the value. Short press ▲ or ▼ to adjust the value, and short press  to confirm and move to the next position.

Note

Hold Cycle: The output time of temperature peak or valley value. For example, if the hold cycle is set to 3, and the output time is set to 2 ms, the device outputs the peak/valley value and lasts for 6 ms (Hold Cycle × Output Time).

6. Short press  to save and return.

4.4.5 Set Oxide Scale Filter

Oxidized and non-oxidized metals have different surface properties, which can cause deviations between the measured temperatures. Enable this function to filter the oxide scale to improve measurement accuracy and reduce the value fluctuation.

1. In the Time Function menu, short press ▲ or ▼ to select **Oxide Scale Filter**.

2. Short press  to turn on the function.

3. Short press  to save and return.





 **Note**

When Oxide Scale Filter is turned on, parameters associated with functions like Output Time, Averaging, Temperature Filter and Peak/Valley Hold cannot be configured, and these parameters stay with default values. When Oxide Scale Filter is turned off, the above parameters can be configured.

4.5 Set Alarm

The alarm types include high, low, and internal overheat alarms. When the target temperature or the device internal temperature reaches the threshold, the alarm is triggered. The alarm appears on the device live view interface, and the temperature value is highlighted in the alarm color (red).

The device can connect with external alarm modules. You can refer 2.2 Cable for wiring instructions.

1. In the live view interface, short press  to go to the main menu.
2. Short press  or  to select **Alarm**, and short press  to enter the alarm setup menu.
3. Select **Alarm Status**, and short press  to enable this function.
4. Set alarm thresholds according to alarm category.





Alarm Category	Description
Max. Temp.	Set Max. Temp. and the alarm is triggered when the target temperature is greater than or equal to this Max. temp.
Min. Temp.	Set Min. Temp. and the alarm is triggered when the target temperature is less than or equal to this Min. Temp.
Alarm Threshold	Set Alarm Threshold , and the alarm is triggered when the device internal temperature is greater than or equal to this upper limit. * The device internal temperature can be viewed on the temperature display interface. The water/air cooled housing can effectively reduce the internal temperature of the device.

5. Short press  to save and return.

4.6 Set Analog Output

The real-time temperature output is achieved through the analog output of the device, which supports 2 sets of outputs.

Prerequisite: The analog output terminal is connected. Wiring instructions can be found in 2.2 Cable.

1. In the live view interface, short press  to enter the main menu.
2. Short press  or  to select **Analog Output**, and short press  to enter the analog output setup menu.
3. Select **Analog Output**, and short press  to enable this function.

Analog Output	Description
Analog Output 1	Fixed current analogue output (4 to 20 mA). You can set the temperature corresponding to the upper and lower limits of the analog current output. That is, the upper limit of output 1 corresponding to 20 mA, and the lower limit of output 1 corresponding to 4 mA.
Analog Output 2	Supports different selection of current/voltage analog outputs. You can set the upper/lower limit temperature corresponding to the upper and lower current output of analog output 2.





4. Short press  to save and return.









Note

For specific output specifications of the two analog outputs, refer to 2.2 Cable.

4.7 Set Focus

The device can focus on the target by semi-auto focusing and manual focusing.

1. In the live view interface, short press  to enter the main menu.
2. Short press  or  to select **Focus**, and short press  to enter the focus setup menu.
3. Select **Focus Mode**, and short press  to switch.

Focus mode	Description
<p>Distance: Enter the object distance to make the device focus properly.</p>	<ol style="list-style-type: none"> 1. Select Focus Adjustment and short press  to enter the focus setup menu. 2. Short press  or  to adjust the value, short press  to confirm and move to the next position to enter the value. 3. Short press  to confirm. <p>Result: The interface prompts <i>Focus Succeeded</i> and returns to the Focus menu.</p>
<p>Semi-Auto: Focus is performed automatically, or can be manually fine-tuned by the Focus button.</p>	<ol style="list-style-type: none"> 1. Select Focus Adjustment and short press  to enter the focus setup menu. 2. Press and hold  to enable semi-auto focus. You can also adjust focus by press Focus+ or Focus-. 3. When the device focuses properly, short press  to confirm and return.





4. Short press  to save and return.

4.8 Set Network

The device supports network communication, and can connect to your computer via serial port. You can configure the functions and monitor the temperature via web or client, etc.

Note

Refer to 3.5.1 Connect via Network Cable for network connection.

1. In the live view interface, short press  to enter the main menu.
2. Short press  or  to select **Network**, and short press  to enter the network setup menu.
3. Select Network Parameters, short press  to set or view parameters.

Network Parameters	Description
IP	View or configure the device default IP address.
Subnet mask	View or configure the default subnet mask.
Gateway	View or configure the device gateway address.
MAC	View the device MAC address.





4. Short press  to save and return.

4.9 Set RS-485

The device supports RS-485 communication. You can modify device parameter, record or query data, or configure functions and monitor temperature through RS-485 serial port on client on your computer.

Note

Refer to 2.2 Cable for RS-485 interface and its pin definition.

1. In the live view interface, short press  to enter the main menu.
2. Short press  or  to select **RS-485**, and short press  to enter the RS-485 setup menu.
3. Select RS-485 parameters, and short press  to set or view the parameter.

RS-485 Parameters	Description
Baud Rate	Default value: 9600. The data can be properly transmitted within the configured baud rate.
Data Bit	Default value: 8.
Stop Bit	Default value: 1.
Parity Bit	Default: Even parity check.
Decoder Type	Default: Modbus-RTU.
Address	Decoder address, default address: 1. Up to 26 devices can be connected.





Note

If not necessary, you can keep the RS-485 default settings.

4. Short press  to save and return.

4.10 Set Laser

You can turn on the laser and aim at the target through the laser light spot.

1. In the live view interface, short press  to enter the main menu.
2. Short press  or  to select **Laser**, and short press  to enter the laser setup menu.
3. Short press  to select **Laser Mode**.

Laser mode	Description
NC	The laser turns off.
NO	The laser is always on.
20 Mins	The laser is on for 20 minutes, then it is off and turns to NC mode.







4. Short press  to save and return.

Note



When the laser is turned on, the live view interface is blocked temporarily, and a laser spot appears in the target area. You can aim the target using the laser spot.

4.11 Set Screen Off

The device screen is locked when it is not operated for a preset screen off time.

1. In the live view interface short press  to enter the main menu.
2. Short press  or  to select **Screen Off**, and short press  to enter the screen off setup menu.
3. Select **Auto Screen Off** and short press  to select time.
4. Short press  to save and return.





Note

When the device screen is locked, short press any key to wake the device. Then long press , and a message to unlock the device prompts up. Short press  to unlock the device.

4.12 Set Advanced Settings

You can set ancillary features, including attenuation filter, lens smudge alarm, and more.

Enter the Advanced Settings menu:









1. In the live view interface, short press  to enter the main menu.
2. Short press  or  to select **Advanced Settings**, and short press  to enter the Advanced Settings menu.

Note

In advanced settings, attenuation filter and lens smudge alarm can only be enabled in 2-color mode.

4.12.1 Set Attenuation Filter

When the detected energy attenuates to a certain degree, the device cannot accurately measure the temperature. The attenuation filter function can determine the attenuation of the energy emitted from the target to the device. When the actual attenuation exceeds the set threshold, the alarm is triggered, and you can adjust in a timely manner to ensure measurement accuracy.

1. In the Advanced Settings menu, short press  or  to select **Attenuation Filter**.
2. Short press  to enter the setup menu.
3. Select **Status**, and short press  to turn on attenuation filter.
4. Select **Threshold**, and short press  to set threshold. Short press  or  to adjust the value. Then short press  to confirm and move to the next position.

Note

Example: setting the attenuation threshold to "95%" means to allow 95% attenuation of energy. The alarm is triggered when the target attenuation is greater than 95%, and the live view interface displays a red warning alert.

5. Short press  to save and return.

Note

The attenuation thresholds for some of the scenarios are listed below as a reference, which can be adjusted according to the site and target conditions.



- Set the threshold to > 95% when measuring targets whose diameter is below 2 mm. For example, when measuring the temperature of the test rod, the

temperature of tungsten wire is usually > 1500 °C, and the filament diameter is < 2 mm.

- Set the threshold to 95% when measuring targets whose diameter is between 2 to 10 mm. For example, when measuring fast moving wire in a steel plant, the target is always shaking.
- Set the threshold to 80% when measuring targets whose diameter is between 30 to 100 mm. For large targets, the threshold can be set to a smaller value to prevent signal interference from stray light when the target is close to the device.
- Set the threshold to 70% when measuring targets whose diameter is > 100 mm. For example, when measuring steel plates in steel mill, much stray light is around the large target.



4.12.2 Set Lens Smudge Alarm

An alarm is triggered when the device lens has an attached object that interferes with the temperature measurement, and a red alert appears in the live view interface. Check and clean the smudge such as dirt on the lens promptly.

1. In the Advanced Settings menu, short press ▲ or ▼ to select **Lens Smudge Alarm**.
2. Short press  to turn on the function.
3. Short press  to save and return.

4.12.3 Set Digital Zoom

You can adjust the digital zoom of the device by following the steps below.

1. In the live view interface, short press ▲ or ▼ to select **Digital Zoom**.
2. Short press  to switch digital zoom.
3. Short press  to save and return.

4.12.4 Set Device Initialization

You can restore the parameters of the device to factory settings.



Caution

Use this function with caution.





1. In the Advanced Settings menu, short press ▲ or ▼ to select **Device Initialization**.
2. Short press  to confirm, and a prompt appears.

3. To confirm the initialization, select **OK**, otherwise select **Cancel**.

4.13 View Device Information

You can view device model, serial number and detailed version information, IP address, and more.

Enter the Device Information menu:

1. In the live view interface, short press  to enter the main menu.
2. Short press  or  to select **Device Information**, and short press  to enter the menu and view device information.

5. Client Operation

With the companion client, you can view real-time image of the device, analyze temperature curve and configure parameters to assist with temperature data management.

Download Address:

Please visit our website (www.hikmicrotech.com) or contact our technical staff to obtain and install HIKMICRO Studio Client (hereinafter referred to as Client) to your computer.



Caution

To ensure complete function of the client, make sure to install client of V1.2.0 and above.

Instructions:

The device connects with the client via IP or RS-485 serial port, and the client supports different configurations depending on the connection method.

- For information about connection over an IP network, refer to 5.1 Network Connection.
- For information about connection over RS-485 serial port, refer to 5.2 Serial Connection.

For more information:

Refer to the User Manual embedded in the client (Click the icon  on the top right corner in the client, and select **Help -> User Manual**) to obtain detailed instructions.



Note

Due to client upgrade, the functions described in the manual may not be consistent with actual functions, and actual functions shall prevail.

5.1 Network Connection

You can connect the device to the client via network cable.

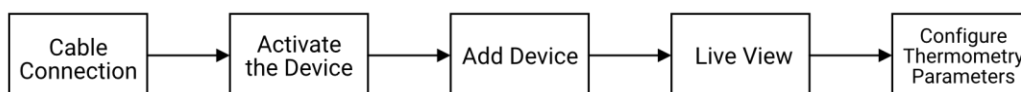

5.1.1 Connect Cable

Connect the cable via network interface.

Refer to 3.5.1 Connect via Network Cable to connect your device to your computer with a network cable, and set the computer and device IP addresses to the same network segment.

5.1.2 Activate Device

To enhance system and data security, activate the device to initialize the device.

Note

Activation via the client is only supported by certain device models. When activating the device, make sure that the device is online and has not been activated before.

1. Open the client, and select **Device Management -> Devices** in the **Maintenance and Management** area of the home page.
2. Click **Online Devices**, and click **Refresh**. Then online devices are displayed in the list.
3. Select one or multiple devices, and click **Activate**.

Note

If you select multiple devices to activate at the same time, only one window will pop up. Typically, the account name and password for the selected devices are the same.

4. Enter the IP Login **Password** and **Confirm Password**.

Caution

- To better protect your privacy and improve product security, we strongly recommend that you set more complex passwords according to the following rules: Password length must be between 8 and 16 digits, and is combination of two or more types of numbers, upper and lower case letters or special characters.
- Please understand that it is your responsibility to properly configure all passwords and security settings of other relevant products.

5. Click **OK**.

6. (Optional) In the list of online devices, click  to modify device information such as name, IP address, port number, and so on.

5.1.3 Add Device

Devices can be added to clients in a variety of ways, including via IP/Domain and IP segment, and online devices searching. After the device is added to the client, you can configure and manage the device remotely.

Add Online Device Automatically

Clients can automatically detect online devices that are on the same network segment as the current computer and obtain device-related information such as IP addresses. With this function, detected online devices can be quickly added to the client. When detected online devices use the same username and password, multiple devices can be selected at the same time and added to the client simultaneously.

When you add a device for the first time, refer to 5.1.2 Activate Device. After the device is activated, click **+Add** to add device.

Add Device via IP/Domain or IP Segment

After the device is activated, you can add the device to the client by entering information such as the IP address or domain name.

If the IP addresses of multiple devices to be added range in the same IP segment and have the same port number, user name, and password, you can add the devices via IP segments. You can quickly add devices to clients by specifying the starting and ending IP addresses of the devices.

1. In the **Maintenance and Management** area of client home page, select **Device Management**- > **Device**.
2. Click **+Add** to open the device adding interface.
3. Select **Add Mode** as **IP/Domain**.
4. Set the parameters in the interface.

Parameters	Description
Name	Depending on the device model or location, you can customize the name.
Address	Device IP address, which can be obtained automatically.
Start/End address	IP Set the IP segment.
Port	The device port number, which is automatically obtained and allows manual modification.
Username	Enter the user name for IP login (not the user name for client login).
Password	Enter the password for the IP login (not the password for client login).

5. Click **Add**, and close the interface, or click **Add and New** to continue adding additional devices in the interface.

5.1.4 Live View

View real-time visible image and monitor real-time temperature and temperature line chart.

Once the device is connected to the client, you can view real-time visible image through the client, keeping up to date with target situation. You can also monitor real-time temperature of the target and browse dynamic temperature line chart.

1. Click **Main View** to enter the live view interface.
2. Select the device in the list on the left and turn on the live view by choosing one of the following three ways.
 - Select a camera and drag it to the window.
 - Double-click the camera in a group.
 - Move your cursor over the camera name, and click .
3. Right-click on the preview window to select the **Display Mode**, and switch to **Live View Mode** or **Temperature Mode**.

 **Note**



In Temperature Mode, only information, e.g. real-time temperature information, is displayed, and live view image is not displayed.

- Click  to hide or display the temperature line chart. When viewing the real-time image, you can view the real-time temperature line chart for monitoring.

5.1.5 Set Thermometry Parameters

Devices that connect with the client via the network can be configured remotely by linking with browser.

Choice 1: Configure web parameters via the client

- In the **Maintenance and Management** area of the client home page, go to **Device Management -> Devices**. In the action bar at the right side of the device list, click  to enter the web configuration page and set thermometry parameters.
- On the client Main View page, select the device and click . Click **Remote Configuration** to open the web configuration page.

Choice 2: Configure web parameters via device IP

Enters the IP address of the device in web browser, and enter the user name and password for login.

1. Enter the IP address of the device in the browser, and the login page pops up.
2. Follow the interface prompts to install the plug-in.
3. Open your browser again and enter the IP address of your device.
4. Enter device IP and input the user name and password, and click **Login** to configure the parameters in the web page.

Note

When you access the web page through a browser, you can click **Help** in the upper-right corner of the web page for detailed instructions on web parameters.

5.2 Serial Connection

Add the device to the client via the RS-485 serial port.

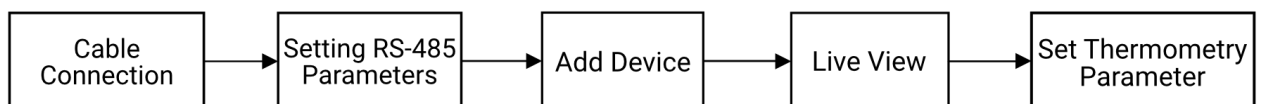

5.2.1 Connect Cable

Use RS-485 serial port for connection.

Refer to 3.5.2 Connect via RS-485 Serial Port, and connect the device to the computer via RS-485 cable.

5.2.2 Set RS-485 Parameters

RS-485 can be used to access control signals, and you can configure parameters of the RS-485 serial port.

Prerequisite: Please make sure that you have configured the RS-485 parameters at the device end. Refer to 4.9 Set RS-485 for details.



Caution

The RS-485 parameters on device end and client end need to be the same, otherwise the client cannot search and add devices for serial access.

1. Start up the client. In the **Maintenance and Management** area of the home page, select **System Configuration -> RS-485**.
2. Set parameters such as baud rate, parity bit, data bit, and stop bit for the selected serial port.
3. Confirm the decoder type (Modbus-RTU by default).
4. Select the CRC mode.

CRC Mode	Description
Big Endian	Big-endian stores more significant bytes in the lower addresses.
Little Endian	Little-endian stores low significant bytes in the lower addresses.

5. Click **Save**.
6. (Optional) Click **Default** to restore to default settings.

5.2.3 Add Device

Add the device to the client via the RS-485 serial port.

Prerequisites:

- (1) The device has been connected to the computer via RS-485 serial port.
- (2) The RS-485 parameters on both the device and the client are configured to the same.

1. In the **Maintenance and Management** area, select **Device Management -> Devices**.

2. Click **+Add** to open the device adding interface.
3. Select **Adding Mode** as **RS-485**.
4. Click the refresh icon in the upper right corner to display the list of devices that have been connected to the computer via serial port and that match the RS-485 parameters.
5. Select the device.
6. Click **Add**, and close the interface, or click **Add and New** to continue adding additional devices in the interface.

Note



After the device is connected to the client via RS-485 protocol, modification on the RS-485 parameters at either device end or at the client end is not supported.

5.2.4 Live View

Once the device is connected to the client, you can monitor the real-time temperature of the target and view the temperature curve on the client.

Note

Devices that connect to the client via serial ports do not support viewing live view image on the client, and only temperature values and related parameters can be obtained.

1. Click **Main View** to enter the live view page.
2. Select the device in the list on the left and start live view by choosing one of the following three ways.
 - Select a camera and drag it to the window.
 - Double-click the camera in a group.
 - Move your cursor over the camera name, and click .
3. You can click  to hide or display the temperature line chart. When viewing the real-time image, you can view the real-time temperature line chart for monitoring.

5.2.5 Set Thermometry Parameters

For devices that connect to the client through serial port, you can view and modify the thermometry parameters in the client and the configuration is saved in the device.

1. Click **Main View** to enter the live view page.
2. Right-click on the live view window and select **Edit Measurement**.

3. Set the thermometry parameters. Refer to 4 Device Operation.

5.3 More Frequently Used Features

Adding a device to the client via network/serial port allows you to remotely manage the device and perform more functions.

5.3.1 Video and Picture

During live view, you can record videos and capture pictures manually.

Note

Only devices that connect to the client via network support recording video and capturing picture.

1. Click **Main View** to open the live view window.
2. Right-click on the live video and click **Start Recording** or **Capture** on the right-click menu.

Result: When the capture or recording is complete, a prompt message appears in the lower right corner of the screen, showing the file storage path. You can go to the local folder to view the file.

3. (Optional) Go to **Maintenance and Management -> System Configuration -> File** to set file storage path.

Note

Capturing raw image and recording raw video are not supported with clients of V1.2.0 and above.

5.3.2 Searching History Temperature

After saving real-time thermometry data to client database, you can query history temperature based on time, visualize results displayed in the form of temperature curve, and export results.

1. In the **Maintenance and Management** area of the home page, select **System Configuration -> General**.
2. Check **Save Temperature Data** and set storage parameters.

Parameters	Description
Save Data For	The time for keeping the data. Once storage duration expires, the data will be deleted.
Temperature Auto-Save Interval	The temperature data is saved automatically according to the storage interval.

3. Click **Save**.

4. On the home page, select **Search History Temp**. Set searching criteria, and then click **Search** to display temperature report on the right.

5. (Optional) Click **Export** to export temperature data, or click **Export Original Record** to export raw temperature data.



Note

Refer to the User Manual in the client (Start up the client, and click  on the top right corner. Then select **Help -> User Manual**) to get detailed instructions for more features.

6. Troubleshooting

During operation or operation of the device, if special conditions occur, perform self-test troubleshooting in the following directions, if the problem is not resolved properly. Please contact our technical staff.

Special cases	Possible causes	Resolution
No image input	The device is not properly plugged into power.	Check that the power supply wiring or PoE supply is OK.
Incorrect temperature measurement results	Incorrect wiring.	Check and confirm wiring.
Incorrect temperature measurement results	The picture is masked.	Clean out obstructions.
Incorrect temperature measurement results	The lens is dirty.	Clean the lens.
Incorrect temperature measurement results	Incorrect emissivity or slope parameter setting.	Check and reset the pyrometer temperature parameters.



HIKMICRO

See the World in a New Way

UD40466B