

## User Manual

*Thermal Scope*

# ***NEOS SERIES***

*V6.0.22 202605*



Contact Us

# CONTENTS

<b>1</b>	<b>Overview .....</b>	<b>1</b>
1.1	Main Function.....	1
1.2	Appearance.....	1
<b>2</b>	<b>Preparation .....</b>	<b>5</b>
2.1	Cable Connection .....	5
2.2	Install Battery .....	5
2.2.1	Battery Instruction .....	5
2.2.2	Battery Installation.....	5
2.3	Mount Device on Rail .....	6
2.4	Power On/Off .....	8
2.5	Auto Screen Off .....	9
2.6	Menu Description .....	10
2.7	App Connection .....	11
2.8	Firmware Status .....	12
2.8.1	Check Firmware Status.....	12
2.8.2	Upgrade Device .....	12
2.9	Zeroing (Overview) .....	13
<b>3</b>	<b>Image Settings .....</b>	<b>15</b>
3.1	Adjust Diopter .....	15
3.2	Adjust Focus.....	15
3.3	Adjust Brightness .....	16
3.4	Adjust Contrast.....	16
3.5	Adjust Tone.....	16
3.6	Adjust Sharpness .....	17
3.7	Select Scene Mode.....	18
3.8	Set Palettes.....	18
3.8.1	Custom Enabled Palettes .....	18
3.8.2	Switch Palettes .....	19
3.9	Adjust Digital Zoom.....	21
3.10	Correct Defective Pixel .....	22
3.11	Set Picture in Picture Mode .....	22
3.12	Set Pitch Scale .....	23
<b>4</b>	<b>Zeroing.....</b>	<b>25</b>
4.1	Set Reticle Mode .....	25
4.2	Select Zeroing Profile.....	25
4.3	Set Reticle.....	26
4.4	Correct Reticle .....	27
4.4.1	Correct Reticle on Device.....	28
4.4.2	Correct Reticle via HIKMICRO Sight.....	29
4.5	Ballistic Calculation for Hunting (LRF Model).....	31

<b>5</b>	<b>Measure Distance (LRF Model)</b> .....	<b>33</b>
<b>6</b>	<b>General Settings</b> .....	<b>35</b>
6.1	Set OSD.....	35
6.2	Set Screen Style .....	35
6.3	Set Brand Logo .....	35
6.4	Burning Prevention.....	36
6.5	Hot Tracking .....	36
6.6	Capture and Video .....	37
6.6.1	Capture Picture .....	37
6.6.2	Set Audio .....	37
6.6.3	Record Video .....	37
6.6.4	Prerecord Video.....	38
6.6.5	Local Album.....	38
6.7	Export Files .....	39
6.7.1	Export Files via HIKMICRO Sight.....	39
6.7.2	Export Files via PC .....	40
<b>7</b>	<b>System Settings</b> .....	<b>42</b>
7.1	Adjust Date .....	42
7.2	Synchronize Time .....	42
7.3	Set Language.....	42
7.4	Set Unit .....	43
7.5	Cast Device Screen to PC.....	43
7.6	Set Screen Lock Passcode .....	44
7.6.1	Enable Passcode.....	44
7.6.2	Change Passcode .....	44
7.7	View Device Information .....	45
7.8	Restore Device.....	45
7.9	Reset Device .....	45
<b>8</b>	<b>Frequently Asked Questions</b> .....	<b>46</b>
8.1	Why is the monitor off? .....	46
8.2	The image is not clear, how to adjust it?.....	46
8.3	Capturing or recording fails. What's the problem?.....	46
8.4	Why the PC cannot identify the device?.....	46

# 1 Overview

HIKMICRO NEOS Thermal Scope is equipped with shutterless technology and the latest Sync Pro algorithm, ensuring excellent targeting accuracy even in challenging moments. With its compact and lightweight design, NEOS also brings great portability especially during long-time hunting.

## 1.1 Main Function

- **HSIS (HIKMICRO Shutterless Image System):** NEOS supports shutterless technology. It is a dynamic learning process without image quality loss. This eliminates the need for periodic calibration pauses, ensuring you never miss a critical moment in the field.
- **Zoom Pro:** It is a deep learning algorithm based on the analysis of abundant hunting scenes images, leading to marvelous images with higher signal-to-noise ratio and impressive details. Equipped with high-performance hardware, it ensures maximum image optimization under digital zoom.
- **Laser Ranging (for LRF Model):** Built-in laser range finder provides an accurate distance between the target and the observation position.
- **Zeroing:** The reticle helps you to aim at the target fast and accurately. See *Zeroing*.
- **App Connection:** The device can capture snapshots, record videos, and set parameters by HIKMICRO Sight app after being connected to your phone via hotspot.

## 1.2 Appearance



### Note

- The appearance of LRF model is different from non-LRF model. Please take the actual product for reference.
  - Pictures in this manual are for illustration purpose only. The actual product may be different.
-

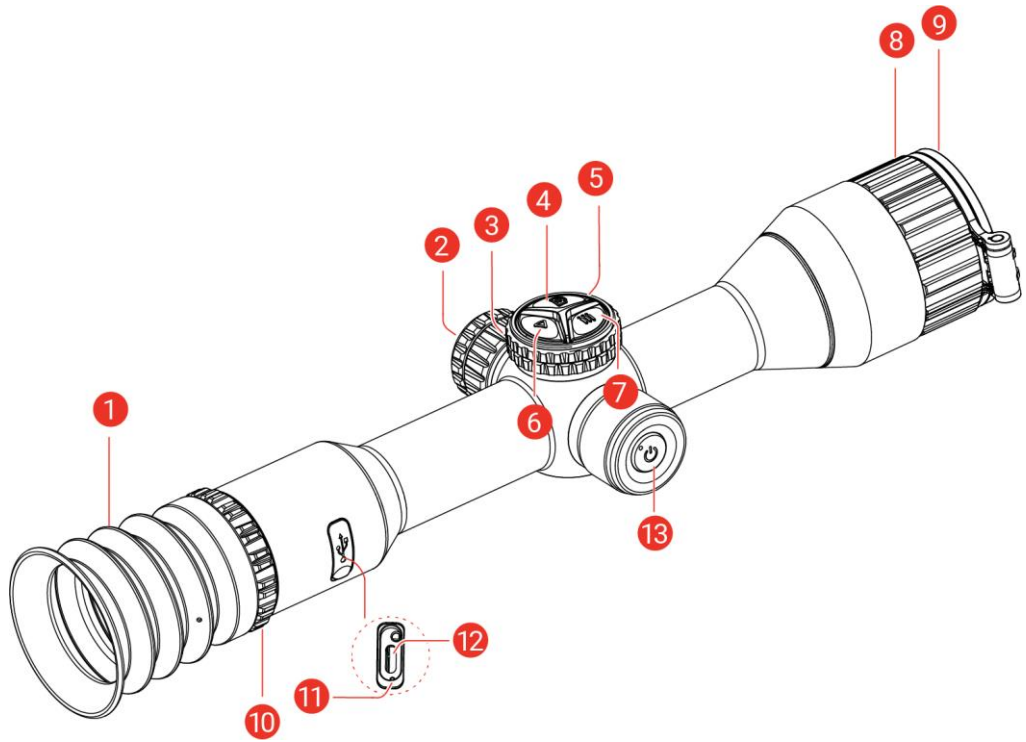

Figure 1-1 Appearance of Non-LRF Model

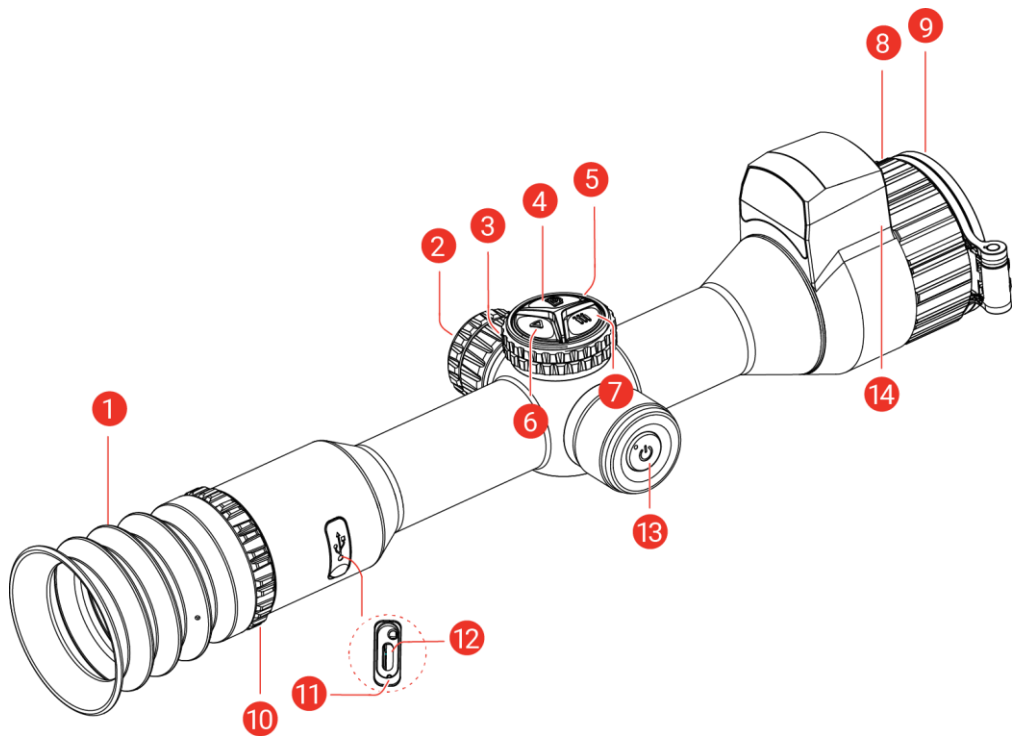





Figure 1-2 Appearance of LRF Model

# Thermal Scope User Manual

Table 1-1 Description of Components

No.	Component	Description
1	Eyepiece	The piece placed closest to the eye to view the target.
2	Battery Compartment	For holding the battery.
3	Wheel	<b>Non-Menu Mode:</b> Rotate to switch digital zoom. <b>Menu Mode:</b> Rotate to move up/move down.
4	 Capture Key	<ul style="list-style-type: none"> <li>● Press: Capture snapshots.</li> <li>● Hold: Start/stop recording videos.</li> </ul>
5	Microphone	To record audio.
6	 Laser Key/FFC Key	<p><b>For LRF Model</b></p> <ul style="list-style-type: none"> <li>● Press: Turn on laser ranging.</li> <li>● Double Press: Turn off laser ranging.</li> <li>● Hold: Correct non-uniformity of display (FFC).</li> </ul> <p><b>For Non-LRF Model</b></p> <p>Hold to Correct non-uniformity of display (FFC).</p>
7	 Menu Key	<p><b>Non-Menu Mode:</b></p> <ul style="list-style-type: none"> <li>● Press: Switch palettes.</li> <li>● Hold: Enter the menu.</li> </ul> <p><b>Menu Mode:</b></p> <ul style="list-style-type: none"> <li>● Press: Confirm/set parameters.</li> <li>● Hold: Save and exit menu.</li> </ul>
8	Focus Ring	Adjusts focus to obtain clear targets.
9	Thermal Lens	For thermal imaging.
10	Diopter Adjustment Ring	Adjusts the dioptic setting
11	Charging Status Indicator	Indicates the charging status of the device. <ul style="list-style-type: none"> <li>● Flashing Red &amp; Green: Error occurred.</li> <li>● Solid Red: Charging.</li> <li>● Solid Green: Fully charged.</li> </ul>
12	Type-C Interface	To connect the device to power supply or transmit data with a type-C cable.
13	 Power Key	<ul style="list-style-type: none"> <li>● Press: Standby mode/Wake up device.</li> <li>● Hold: Power on/off.</li> </ul>





## Thermal Scope User Manual

---

No.	Component	Description
14*	Laser Rangefinder ( <i>LRF Model</i> )	Measures the distance to the target with laser.
4 + 6	Capture Key + Laser/FCC Key	Hold to lock/unlock the wheel.



### Note

- The power indicator stays solid red when the device is on.
  - When the auto screen off function is enabled, if you press  to enter standby mode, you can also tilt or rotate the device to wake up the device. Refer to Auto Screen Off for detailed operation.
  - When the wheel is locked/unlocked, the icon  /  will be displayed.
  - Only  and  take effect when the wheel is locked.
-

## 2 Preparation

### 2.1 Cable Connection

Connect the device and power adapter with a Type-C cable to power on the device. Alternatively, connect the device and PC to export files.

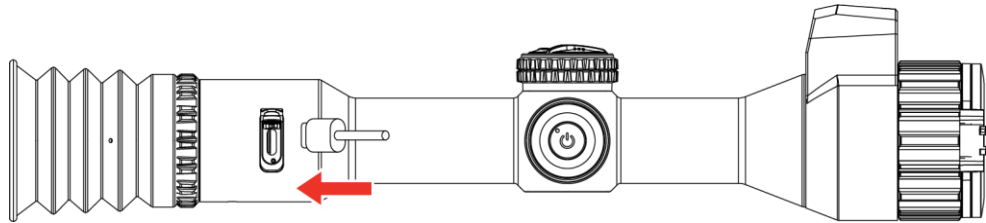





Figure 2-1 Cable Connection



#### Note

- Charge the device for more than 4 hours before first use.
  - Only the built-in battery will be charged via the type-C cable. Use the battery charger to charge the external battery.
  - The priority for power supply is given to the external battery first, followed by the built-in battery.
  -  on the top of the battery icon /  on the screen means the device is currently powered by the built-in battery/external battery.
- 

### 2.2 Install Battery

#### 2.2.1 Battery Instruction

- Remove the external battery if the device is not used for a long time.
- The device comes with an external rechargeable 18650 battery and a built-in rechargeable lithium-ion battery.
- The external battery size should be 19 mm × 70 mm, the rated voltage is 3.635 V, and the battery capacity is 3300 mAh.
- The built-in battery size should be 23 mm × 67 mm, the rated voltage is 3.635 V, and the battery capacity is 3350 mAh.

#### 2.2.2 Battery Installation

Insert the batteries into the battery compartment.

##### Steps

1. Turn the battery cover counterclockwise to loosen it.

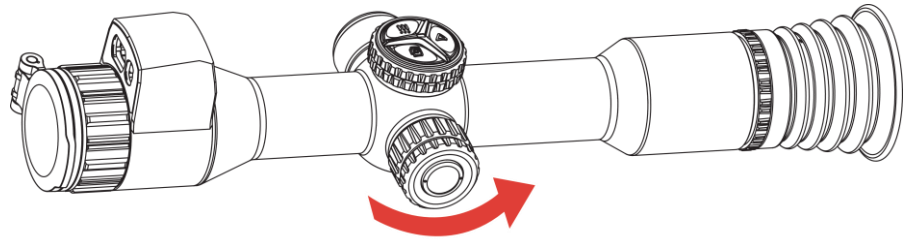

Figure 2-2 Loosen the Cover

2. Insert the battery into the battery compartment with the positive mark inward.

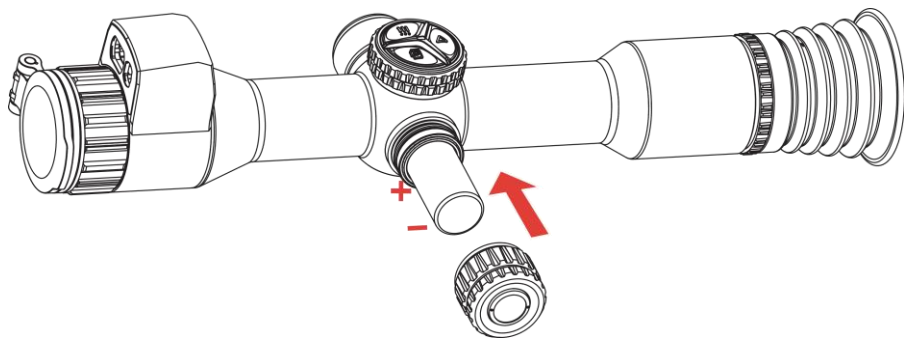

Figure 2-3 Insert the Battery

3. Turn the battery cover clockwise to tighten it.

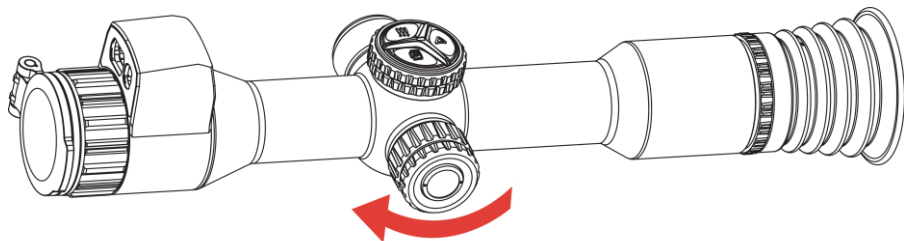

Figure 2-4 Tighten the Cover

## 2.3 Mount Device on Rail

### *Steps*

1. Unscrew the ring top with an Allen wrench.

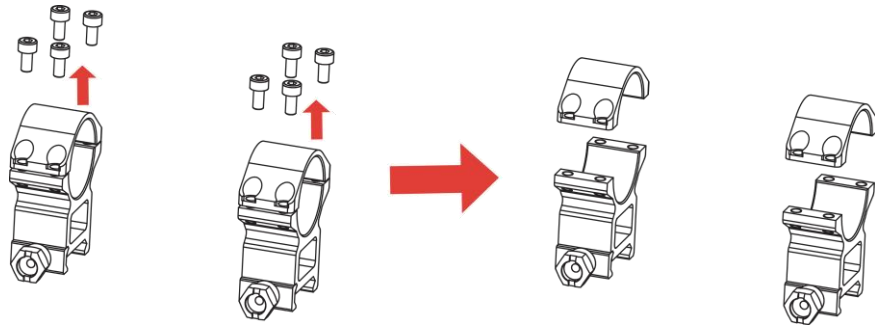

Figure 2-5 Unscrew the Ring Top

2. Place the device in the bottom half of the ring, and align the top holes with bottom holes.

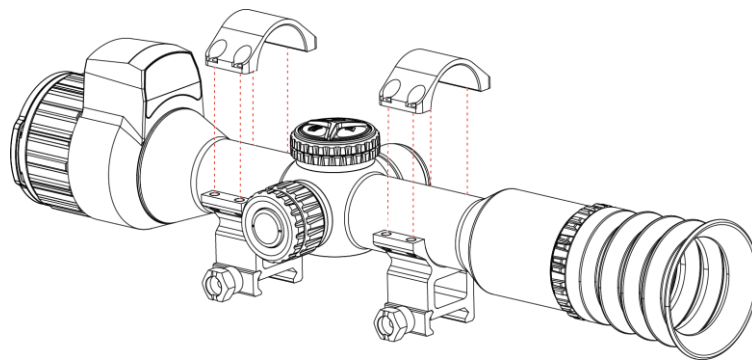

Figure 2-6 Place the Device in the Ring

3. Insert and tighten the screws.

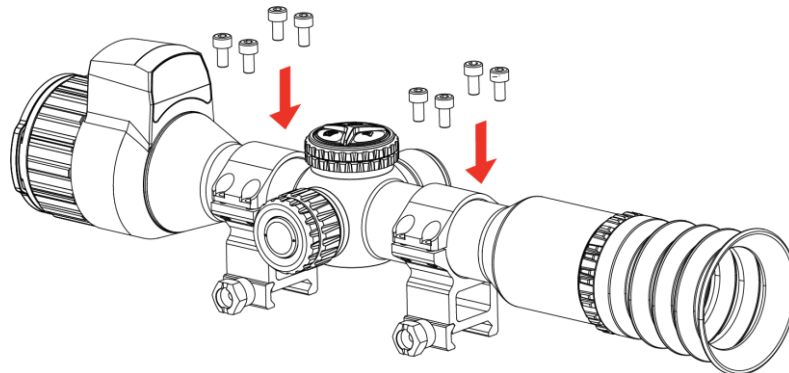

Figure 2-7 Tighten the Screws

4. Loosen the screws on the bottom half of the ring.

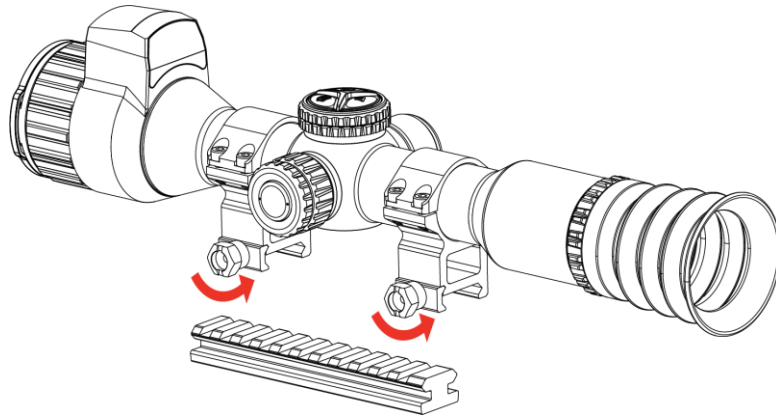

Figure 2-8 Loosen the Screws

5. Attach the bottom half of the ring to the rail, and tighten the screws on the ring. Make sure the device stays level.

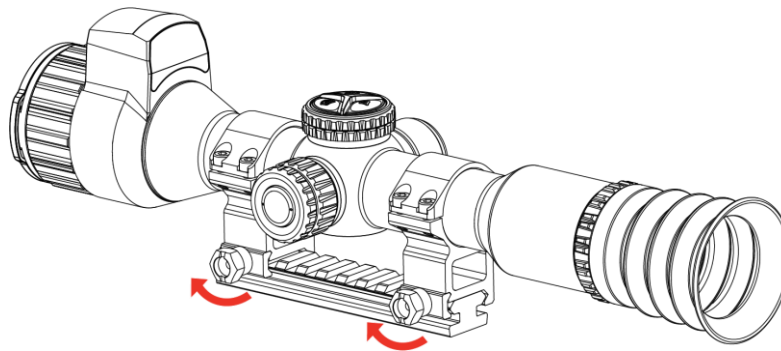

Figure 2-9 Tighten the Screws



### Note

- The ring may vary according to different models. Please refer to the actual product.
  - Please purchase the ring separately.
  - Use lint-free cloth to clean the device base and the rail.
- 

## 2.4 Power On/Off

### Power On

When the device is connected to a power adapter or the battery power is sufficient, hold  to power on the device.

### Power Off

When the device is turned on, hold  to power off the device.









## Note

- Power-off countdown will appear when you power off the device. You can press any key to interrupt the countdown and cancel the power-off.
  - Automatic low battery power-off cannot be canceled.
- 

## Auto Power Off







You can set the auto power off time for your device.

### Steps

1. Hold  to show the menu.
  2. Go to  **Advanced Settings**.
  3. Rotate the wheel to select , and press  to enter the configuration interface.
  4. Rotate the wheel to select the auto power off time as needed, and press  to confirm.
  5. Hold  to save and exit.
- 



## Note



- See the battery icon for the battery status.  means the battery is fully charged,  /  means that the battery is low,  means the battery charging is abnormal, and  /  means the battery is not installed or out of power.
  - When the low power note shows, charge the battery.
  - The auto power off takes effect only when the device enters the standby mode and the device isn't connected with HIKMICRO Sight app at the same time.
  - The auto power off countdown will start again when the device reenters standby mode, or the device is restarted.
- 

## 2.5

## Auto Screen Off

Auto screen off function darkens the screen to save energy and extend battery life.

## Steps

1. Enable auto screen off.
  - 1) Hold ☰ to show the menu.
  - 2) Go to  **Advanced Settings**, and rotate the wheel to select .
  - Press ☰ to enable auto screen off.
  - 3) Hold ☰ to save settings and exit.
2. Use one of the following methods to switch the device to standby mode when the display is turned on:
  - Tilt the device downwards more than 70°.
  - Rotate the device horizontally more than 45°.
  - Keep the device still and do not move it for 5 minutes.
3. Use one of the following methods to wake up the device when the display is turned off:
  - Tilt the device downwards from 0° to 60° or upwards.
  - Rotate the device horizontally from 0° to 40°.
  - Press  to wake up the device.

## 2.6 Menu Description

In the live view interface, hold ☰ to show the menu.

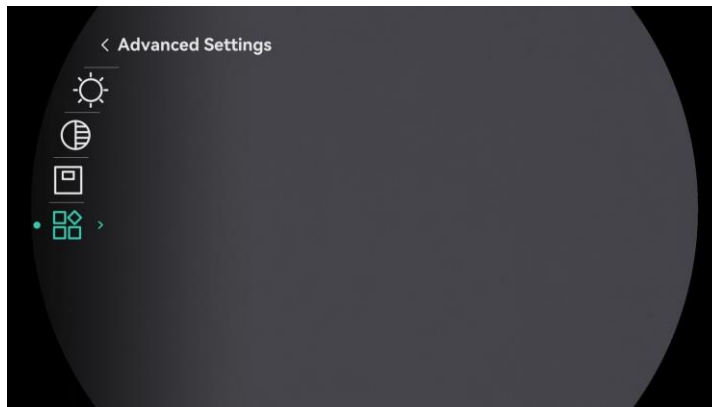

Figure 2-10 Device Menu (Round Screen Style)

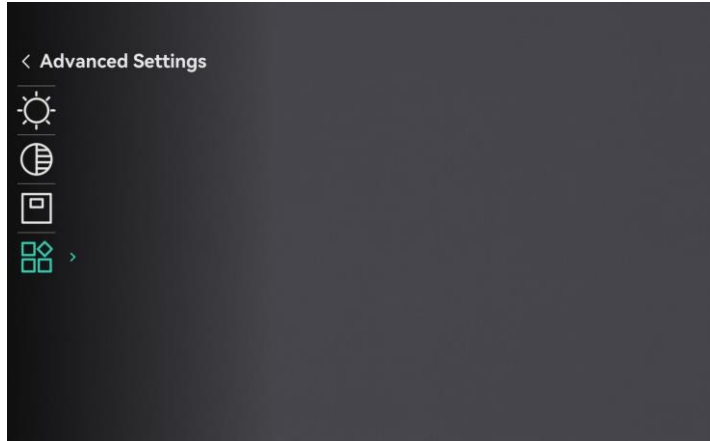

Figure 2-11 Device Menu (Square Screen Style)

## 2.7 App Connection

Connect the device to the HIKMICRO Sight app via hotspot, then you can capture picture, record video, or configure parameters on your phone.

### ***Before You Start***

Confirm **Remote Access** is enabled on the device. Hold ☰ to enter the menu, and go to **Advanced Settings > Remote Access**.

### ***Steps***



1. Search for HIKMICRO Sight on App Store (iOS System) or Google Play™ (Android System) to download it, or scan the QR code to download and install the app.



Android System



iOS System

2. Hold ☰ to show the menu.
3. Go to  **Advanced Settings**, and rotate the wheel to select .
4. Press ☰ to enter the setting interface.
5. Rotate the wheel to select **Hotspot**. The hotspot function is enabled and the hotspot password is displayed.
6. Turn on the WLAN of your phone and connect to the hotspot.

- Hotspot Name: HIKMICRO\_Serial No.
  - Hotspot Password: Go to **Hotspot** in the menu to check the password.
7. Open the app, and confirm the connection PIN code on the device to connect your phone with the device. You can view the interface of device on your phone.



### Note

- When the device is connected to your phone, you can change the hotspot password via the HIKMICRO Sight app.
  - The hotspot password will be updated when you reset the device (refer to **Reset Device**). In this case, you need to reconnect to the device hotspot.
  - The hotspot will be turned off if there is no connection for over 10 minutes.
- 

## 2.8 Firmware Status

### 2.8.1 Check Firmware Status

#### Steps

1. Open HIKMICRO Sight and connect your device to the app.
2. Check if there is an upgrade prompt on the device management interface. If there is no upgrade prompt, the firmware is the latest version. Otherwise, the firmware is not the latest version.

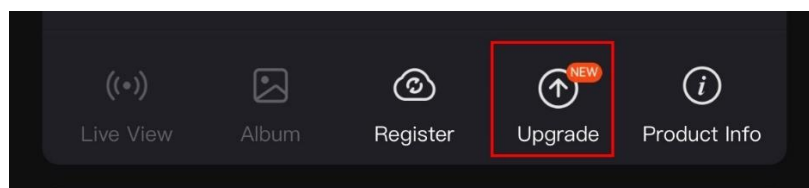

Figure 2-12 Check Firmware Status

3. (Optional) If the firmware is not the latest version, upgrade the device. See **Upgrade Device**.

### 2.8.2 Upgrade Device

#### Upgrade Device via HIKMICRO Sight

#### Steps

1. Open HIKMICRO Sight and connect your device to the app.
2. Tap the upgrade prompt to enter the firmware upgrade interface.
3. Tap **Upgrade** to start upgrade.



### Note

The upgrading operation may vary due to app updates. Please take the actual app version for reference.





---

## Upgrade Device via PC

### *Before You Start*

Please get the upgrade package first.

### *Steps*

1. Hold  to show the menu.
2. Go to  **Advanced Settings**, and rotate the wheel to select .
3. Press  to enter the configuration interface.
4. Rotate the wheel to select **USB Flash Drive**.
5. Connect the device to your PC with the cable.
6. Open the detected disk, copy the upgrade file and paste it to the root directory of the device.
7. Disconnect the device from your PC.
8. Reboot the device, and the device upgrades automatically. The upgrading process will be displayed in the main interface.



### Caution

During the upgrade package transmission, make sure the device is connected to your PC. Otherwise, it may cause unnecessary upgrade failure, firmware damage, etc.

---

## 2.9 Zeroing (Overview)

You can enable the reticle to view the position of the target. Functions such as freeze and zoom help to adjust the reticle more accurately. See **Zeroing** for detailed instructions.



Figure 2-13 Zeroing

## 3 Image Settings

### 3.1 Adjust Diopter

#### Steps

1. Power on the device.
2. Open the lens cover.
3. Hold the device and make sure the eyepiece covers your eye.
4. Adjust the diopter adjustment ring until the OSD information or image is clear.

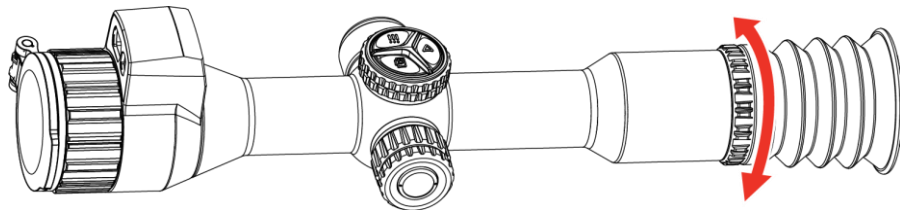

Figure 3-1 Adjust Diopter



#### Note

When adjusting diopter, DO NOT touch the surface of lens to avoid smearing the lens.

---

### 3.2 Adjust Focus

#### Steps

1. Power on the device.
2. Hold the device and make sure the eyepiece covers your eye.
3. Adjust the focus ring until the image is clear.

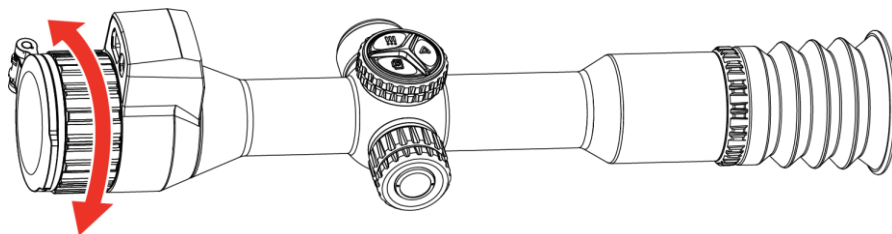

Figure 3-2 Adjust Focus



### Note





When focusing, do not touch the surface of lens to avoid smearing the lens.

---

## 3.3 Adjust Brightness





You can adjust the display brightness of the screen in the menu.

### Steps

1. Hold  to show the menu.
2. Rotate the wheel to select  and press  to confirm.
3. Rotate the wheel to adjust display brightness.
4. Hold  to save the settings and exit.

## 3.4 Adjust Contrast

### Steps

1. Hold  to show the menu.
2. Rotate the wheel to select  and press  to confirm.
3. Rotate the wheel to adjust contrast.
4. Hold  to save the settings and exit.

## 3.5 Adjust Tone

### Steps





1. Hold  to show the menu.
2. Go to  **Advanced Settings**, rotate the wheel to select  and press  to confirm.
3. Rotate the wheel to select a tone. **Warm** and **Cold** can be selected.
4. Hold  to save and exit.



Figure 3-3 Warm Tone



Figure 3-4 Cold Tone

## 3.6 Adjust Sharpness

### Steps





1. Hold  to show the menu.
2. Go to  **Advanced Settings**, rotate the wheel to select  and press  to confirm.
3. Rotate the wheel to adjust sharpness.
4. Hold  to save settings and exit.



Figure 3-5 Sharpness 1









Figure 3-6 Sharpness 5

## 3.7 Select Scene Mode

You can select proper scene according to actual using scene to improve the display effect.

### Steps





1. Hold  to show the menu.
2. Go to  **Advanced Settings**, rotate the wheel to select  and press  to confirm.
3. Rotate the wheel to switch scene mode and press  to confirm.
  - **Observation**: Observation mode is recommended in normal scene.
  - **Detection**: Detection mode is recommended in hunting environment.
4. Hold  to save the settings and exit.

## 3.8 Set Palettes

You can select different palettes to display the same scene in different effects.

### 3.8.1 Custom Enabled Palettes

#### Steps

1. Hold  to show the menu.
2. Go to  **Advanced Settings**, rotate the wheel to select  and press  to confirm.
3. Rotate the wheel to select the palettes you need, and press  to enable them.



## Note

At least one palette should be enabled.

---

4. Hold ☰ to save the settings and exit.

## 3.8.2

### Switch Palettes

- LRF model: Press ☰ in live view interface to switch the selected palettes.

#### White Hot

The hot part is light-colored in view. The higher the temperature is, the lighter the color is.



#### Black Hot

The hot part is black-colored in view. The higher the temperature is, the darker the color is.



#### Red Hot

The hot part is red-colored in view. The higher the temperature is, the redder the color is.



**Fusion**

From high temperature to low temperature, the image is colored in from white, yellow, red, pink to purple.



**Red Monochrome**

The whole image is red colored. The higher the temperature is, the lighter the color is.



**Green Monochrome**







The whole image is green colored. The higher the temperature is, the lighter the color is.



### 3.9 Adjust Digital Zoom

You can zoom in and out the image by using this function. Rotate the wheel in the live view interface to switch the digital zoom ratio.

#### Steps

1. Hold  to show the menu.
2. Go to  **Advanced Settings**, and rotate the wheel to select .
3. Press  to enter the setting interface, and rotate the wheel to select .
4. Press  to enter the setting interface, and rotate the wheel to set zoom step.
5. Hold  to save settings and exit.
6. In the live view interface, rotate the wheel to switch the digital zoom of the device.







#### Note

- When switching the digital zoom ratio, the left interface displays the actual magnification.
  - The zoom ratio may vary according to different models. Please take the actual product for reference.
-

## 3.10 Correct Defective Pixel

The device can correct the defective pixels on the screen which are not performed as expected.

### Steps



1. Hold  to show the menu.
2. Go to  **Advanced Settings**, rotate the wheel to select  **DPC** and press  to confirm.
3. Press  to select the **X** or **Y** axis. Then rotate the wheel to set the coordinates until the cursor reaches the dead pixel.



### Note

If you select **X** axis, the cursor moves left and right; if you select **Y** axis, the cursor moves up and down.

---

4. Press  twice to correct the dead pixel.
5. Hold  to save and exit.







### Note

- The selected defective pixel can be magnified to view it more easily.
  - If the screen OSD blocks the defective pixel, move the cursor to reach the pixel and the device will perform mirror display automatically.
- 

## 3.11 Set Picture in Picture Mode

### Steps

1. Hold  to show the menu.
2. Rotate the wheel to select  and press  to enable it. The details are shown in the upper center of the interface.
3. Hold  to exit.

When the PIP is enabled, the PIP view center follows the priority below: ballistic calculation recommended aiming point > reticle center > laser rangefinding reticle > live view center.

- When ballistic calculation is enabled, the PIP view centers on the recommended aiming point.

- When ballistic calculation is disabled and reticle is enabled, the PIP view centers on the reticle center.
- When reticle and ballistic calculation are disabled and laser ranging is enabled, the PIP view centers on the laser rangefinding reticle.
- When reticle, ballistic calculation, and laser ranging are all disabled, the PIP view shows the center of the live view in detail.



Figure 3-7 Picture in Picture Mode







### Note

- If the PIP function is enabled, only the PIP view zooms when adjusting the digital zoom ratio.
  - The zoom ratio will be temporarily displayed in the PIP view when adjusting the digital zoom.
  - Ballistic calculation and laser ranging are available only on LRF model.
- 

## 3.12 Set Pitch Scale

You can enable pitch scale to view the device inclination angle in the live view.

### Steps

1. Hold  to show the menu.
2. Go to  **Advanced Settings**, and rotate the wheel to select .
3. Press  to enable the pitch scale.
4. Hold  to save and exit.

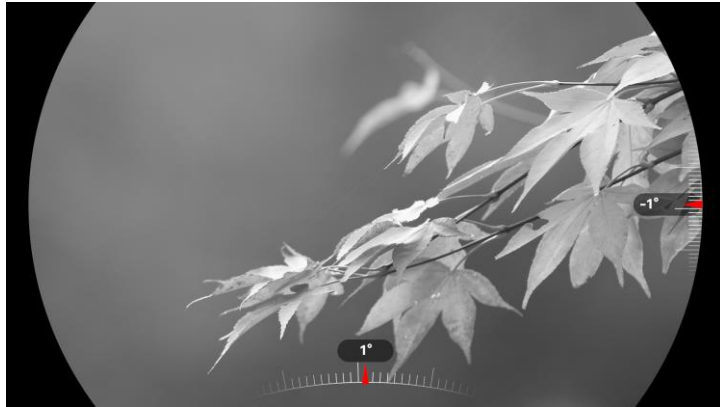







Figure 3-8 Pitch Scale

## 4 Zeroing

### 4.1 Set Reticle Mode

You can select a reticle mode according to your preference and different situations.

#### Steps

1. Hold  to show the menu.
2. Go to  **Advanced Settings**, and rotate the wheel to select .
3. Press  to enter the setting interface, and rotate the wheel to select a reticle mode.
  - **Central Reticle:** This mode centers around the reticle when switching the digital zoom ratio, with the reticle and zoomed image moved to the center of the display.
  - **Fixed Reticle:** This mode centers around the reticle when switching the digital zoom ratio, with the reticle position unchanged.
4. Hold  to save and exit.





#### Note



- The actual zoom ratio returns to the min. value when switching the reticle mode.
  - The beginning continuous zoom ratio in central reticle mode is about 2× of that in fixed reticle mode.
  - The zoom ratio may vary according to different models. Please take the actual product for reference.
- 

### 4.2 Select Zeroing Profile

You can configure and save the reticle settings in zeroing profiles according to various situation.

#### Steps

1. Hold  to show the menu.
2. Go to  **Advanced Settings**, and rotate the wheel to select .

3. Press  to enter the setting interface, and rotate the wheel to select a zeroing profile.
4. Hold  to save and exit.



## Note

There are 5 zeroing profiles in total, and you can configure 5 reticles in each zeroing profile.

---

## 4.3 Set Reticle

You can select a reticle in the current zeroing profile, and set parameters such as type, color, and position for the reticle.

### *Before You Start*

Select a zeroing profile first.

### *Steps*







1. Hold  to show the menu.
2. Go to  **Advanced Settings**, and rotate the wheel to select  . Press  to enter the setting interface.
3. Select  **Zeroing**, and press  to confirm. Rotate the wheel to select a reticle No. You can select **OFF** to turn off the reticle.







Figure 4-1 Using a Reticle



## Note

The right top of the image displays the reticle information. For example, A3-100m means you are using the No. 3 reticle in zeroing profile A, and the set distance is 100 m.

---

4. Select  **Bullet**, and press  to set the bullet name. Press  to switch the digit and rotate the wheel to change the value, letter or symbol.
5. Select  **Type**, and press  to confirm. Rotate the wheel to select the reticle type. 11 types of reticles can be selected.



### Note

When you enable PIP, the detail of reticle type 11 will not be displayed in PIP view.

---





6. Select  **Opacity**, and press  to confirm. Rotate the wheel to select the reticle opacity.



### Note

When the reticle type 5 is selected, the opacity cannot be set.

---

7. Select  **Reticle Color**, and press  to confirm. Rotate the wheel to set the reticle color.
8. Select  **Reticle Center Color**, and press  to confirm. Rotate the wheel to set the reticle center color.
9. (Optional) Repeat 3 to 7 to set other reticles in this zeroing profile.
10. Hold  to save settings and exit.



### Note

- 5 reticles can be configured in a zeroing profile.
  - If the PIP function is enabled, the aimed target can be magnified on the interface.
  - In black hot mode and white hot mode, if you set the reticle color as white or black, the color of the reticle will be inverted automatically to better aim at the target.
- 

## 4.4 Correct Reticle

Correcting the reticle can help you aim at the target with high accuracy by marking the offset between the big reticle and small reticle. Functions such as **Freeze** and **Zoom** help to adjust the reticle more accurately.

## 4.4.1 Correct Reticle on Device

### *Before You Start*

- Select a zeroing profile first.

### *Steps*



















1. Hold  to show the menu.
2. Go to  **Advanced Settings**, and rotate the wheel to select  .  
Press  to enter the setting interface.
3. Select  **Zeroing**, and press  to confirm. Rotate the wheel to select a reticle you want to correct.
4. Select  **Correction**, and press  to enter the setting interface.
5. Set the distance to the target.
  - 1) Rotate the wheel to select  **Distance**.
  - 2) Press  to select the digit you want to set.
  - 3) Rotate the wheel to change the number. Hold  to finish the setting.
6. Select  **Zoom**, and press  to confirm. Rotate the wheel to set the digital zoom ratio.
7. Aim at the target and pull the trigger. Align the reticle with the point of impact.
  - 1) Aim the big reticle at the target.
  - 2) Select  **Freeze**. Press  to enable the function.
  - 3) Select  and rotate the wheel to set the coordinates until the big reticle aligns with the point of impact. Press  to select axis. If you select X, the reticle moves left and right; if you select Y, the reticle moves up and down. Hold  to finish setting.



Figure 4-2 Enable Freeze



### Note

When enabling the freeze function in reticle, you can adjust the position of the cursor on a frozen image. This function can prevent image flutter.

---

8. Hold  to exit the setting interface according to the prompt.
  - **OK:** Save the parameter and exit.
  - **CANCEL:** Exit without saving the parameters.
9. Pull the trigger again to verify that the aiming point aligns with the point of impact.
10. (Optional) Repeat 3 to 9 to set the position for other reticles in this zeroing profile.

## 4.4.2 Correct Reticle via HIKMICRO Sight

You can also correct the reticle by HIKMICRO Sight app.

### ***Before You Start***

- Install HIKMICRO Sight on your phone.

### ***Step***

1. Open HIKMICRO Sight and connect your device to the app.

2. Tap **Product Info**, and tap **Zeroing** to enter configuration interface.
3. Set reticle to the target.
  - 1) After synchronizing data from the device, select a zeroing profile.
  - 2) Select a reticle you want to correct.
  - 3) Input the number to set the distance to the target.
  - 4) Select digital zoom ratio.
4. Aim at the target and pull the trigger.
5. Measure the deviation of the point of impact from the target and enter the values to adjust the position of reticle to ensure the big reticle aligns with the point of impact. Tap **Apply** to apply the parameters to device.

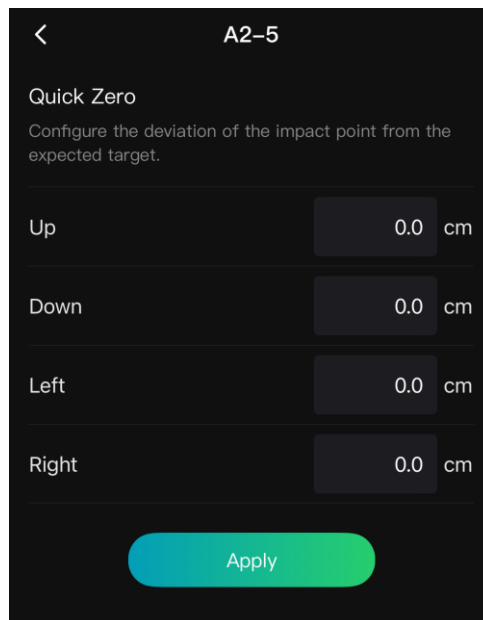

Figure 4-3 Quick Zero

6. Pull the trigger again and check the point of impact. Ensure the big reticle aligns with it.
7. Tap **Completed** to finish zeroing.

### **Result**

The position of the reticle is saved and synchronized to your device, so you can check it on your device.



## Note

- When you enter the zeroing setting interface on your app, the device will return to the live view interface automatically.
  - The zeroing operation may vary due to app updates. Please take the actual app version for reference.
- 

## 4.5

### Ballistic Calculation for Hunting (LRF Model)

The function helps you have a better experience in various conditions. Multiple parameters are used in calculation to ensure precision and flexibility of use.



## Note















This function is only available on LRF model.





---

### ***Before You Start***

- Make sure the reticle is enabled.
- Make sure you have finished zeroing.

### ***Steps***

1. Hold  to show the menu.
2. Go to  **Advanced Settings**, and rotate the wheel to select .  
Press  to enter the setting interface.
3. Rotate the wheel to select . Press  to enter the setting interface.
4. Press  to enable this function.
5. Select  **Aim Point Style**. Press  and rotate the wheel to set the aim point style.
6. Select  **Aim Point Color**. Press  and rotate the wheel to set the aim point color.
7. Select  and press  to enter the parameter configuration interface. Rotate the wheel to select the following parameters, and press  to set or input the data.
  - Drag Model: Set the bullet-specific drag model, e.g. G1, G7 and GS.
  - Initial Velocity: The velocity varies in different conditions.

- Altitude: Set this to your normal altitude.
  - Temperature: Set this to your normal temperature.
  - Ballistic Coefficient: The measure of its ability to overcome air resistance.
  - Sight Height: The distance between the bore and the center of the lens.
  - Wind Direction: Set this to your normal wind direction.
  - Wind Speed: Set this to your normal wind speed.
8. Press  to switch digit, and rotate the wheel to change the number.
9. Hold  to save and exit.
10. Press  to turn on laser ranging, aim the cursor at the target, and press  again to measure the target distance. The screen will display the recommended aiming point, drop distance, and wind drift in the interface.
11. (Optional) To adjust the distance, repeat the above step.



### Note

- The more parameters you specify, the more accurate the recommended aiming point will be.
  - The drop distance and wind drift are related to the input parameters. Please refer to the actual situation.
  - Continuous laser ranging is not available when enabling ballistic calculation.
  - Ballistic Calculation can also be set via HIKMICRO Sight app. Please refer to the actual interface
-















## 5 Measure Distance (LRF Model)

The device with an LRF module can detect the distance between the target and the observation position with laser.

### **Before You Start**

When measuring the distance, keep the hand and the position steady. Otherwise, the accuracy may be affected.

### **Steps**

1. Hold  to show the menu.
2. Go to  **Advanced Settings**, and rotate the wheel to select  .  
Press  to enter the setting interface.
3. Go to  to select a laser ranging mode and press  to confirm.  
**Once** and **Continuous** are selectable.
  - **Once**: Measure the distance once.
  - **Continuous**: Measure the distance continuously, and the measurement duration can be selected. The measurement result will be refreshed every second.
4. (Optional) Select  and press  to enable/disable the THD display. When enabled, the THD (True Horizontal Distance) to the target will be displayed when performing laser ranging.
5. You can set  **Rangefinding Reticle Style** or  **Rangefinding Reticle Color** according to your necessity. Press  to confirm and rotate the wheel to select the rangefinding reticle style or rangefinding reticle color.
6. Hold  to return to the live view interface.
7. Press  to turn on laser ranging, aim at the target, and press  again to measure the target distance.



### Note

- Double-press  to turn off laser ranging.
  - Laser ranging mode cannot be set when enabling Ballistic Calculation, and continuous laser ranging is not available.
  - When Continuous laser ranging is in use, it will be switched to Once after enabling Ballistic Calculation. When Ballistic Calculation is turned off, the laser ranging mode will be reverted to Continuous.
- 

### Result

The distance measurement result is displayed on the image.



Figure 5-1 Distance Measurement Result

- When THD is enabled, the straight-line distance is displayed first, followed by the THD. As shown in the figure above, **216m** is the straight-line distance and **200m** is the THD.
  - The ranging result will be displayed as “000” if laser ranging fails.
- 



### Caution

The laser radiation emitted from the device can cause eye injuries, burning of skin or inflammable substances. Before enabling the laser ranging function, make sure that no human or inflammable substances are in front of the laser lens, and that the laser lens is not obstructed.







---

## 6 General Settings

### 6.1 Set OSD

This function can display or hide the OSD information on the live view interface.

#### **Steps**

1. Hold  to show the menu.
2. Go to  **Advanced Settings**, and rotate the wheel to select .
3. Press  to enter OSD setting interface.
4. Rotate the wheel to select the **Time**, **Date**, or **OSD**, and press  to turn on or turn off the selected OSD information.
5. Hold  to save and exit.



#### **Note**





If you turn off **OSD**, all OSD information on the live view will not be displayed.

---

### 6.2 Set Screen Style

You can select screen style according to your preference.





#### **Steps**

1. Hold  to show the menu.
2. Go to  **Advanced Settings**, and rotate the wheel to select .
3. Press  to confirm. Rotate the wheel to select screen style modes. **Round** and **square** are selectable.
4. Hold  to save according to the prompt.

### 6.3 Set Brand Logo

You can add brand logo to the live view interface, snapshots, and videos.

#### **Steps**

1. Hold  to show the menu.
2. Go to  **Advanced Settings**, and rotate the wheel to select .
3. Press  to enable **Brand Logo**.
4. Hold  to save the settings and exit.





### **Result**

The brand logo is displayed at the bottom left of the image.

## 6.4 Burning Prevention

Avoid direct sunlight and enable the burning prevention function to reduce the risk of sensor damage from the heat.





### **Steps**

1. Hold  to show the menu.
2. Go to  **Advanced Settings**, and rotate the wheel to select .
3. Press  to enable or disable the **Burn-Prevention** function.
4. Hold  to save the settings and exit.

## 6.5 Hot Tracking

The device can detect the highest temperature spot in the scene and mark it on display.

### **Steps**

1. Hold  to show the menu.
2. Go to  **Advanced Settings**, and rotate the wheel to select .
3. Press  to enable the function and mark the spot of highest temperature.
4. Hold  to save settings and exit.

### **Result**



When the function is enabled,  displays in the spot of highest temperature. When the scene changes, the  moves.



Figure 6-1 Hot Tracking

## 6.6 Capture and Video

### 6.6.1 Capture Picture

In the live view interface, press  to capture picture.







#### Note

- When capturing succeeds, the image freezes for a second and a prompt shows on the display.
  - For exporting pictures, refer to ***Export Files***.
- 

### 6.6.2 Set Audio

If you turn on the audio function, the sound will be recorded with the video. When there is too loud noise in the video, you can turn off this function.

#### Steps

1. Hold  to show the menu.
2. Go to  **Advanced Settings**, and rotate the wheel to select .
3. Press  to enable or disable this function.
4. Hold  to save settings and exit.

### 6.6.3 Record Video

#### Steps



1. In the live view interface, hold  to start recording.



Figure 6-2 Start Recording





The recording time is displayed on the top.

2. Hold  again to stop recording.

## 6.6.4 Prerecord Video

After you enable this function and select the prerecording time, the device can automatically start recording the 5, 10 or 15 seconds before the recoil-activation and end recording the 5, 10, 15 or 25 seconds after the recoil-activation.



### Steps

1. Hold  to show the menu.
2. Go to  **Advanced Settings**, and rotate the wheel to select .
3. Press  to enter the setting interface. Rotate the wheel to switch the prerecording time. 5+5s, 10+10s, 15+15s, 15+25s are selectable. You can also select **OFF** to turn off the function.
4. Hold  to save settings and exit.

## 6.6.5 Local Album

Captured images and recorded videos are automatically stored in the device, and you can view the files in local albums.

### Steps



1. Hold  to show the menu.
2. Go to  **Advanced Settings**, and rotate the wheel to select .



### Note





The albums are automatically created and named by year + month. The local pictures and videos of a certain month are stored in the corresponding album. For example, the pictures and videos of May in 2026 are saved in the album named 202605.

---

3. Rotate the wheel to select an album and press  to enter it.
4. Rotate the wheel to select a file to view.
5. Press  to view the selected file.



### Note

- Files are arranged in chronological order, with the most recent at the top. If you fail to find the most recently taken snapshots or videos, please check the time and date settings of your device. When you view files, you can switch to other files by rotating the wheel.
  - When you view files, you can press  to turn to next page, and press  to go back to previous page.
  - When you view videos, you can press  to play or stop the video.
  - For deleting an album or a file, you can press  +  to call the dialogue box, and delete the album or file according to the prompt.
- 

## 6.7 Export Files

### 6.7.1 Export Files via HIKMICRO Sight

You can access device albums and export files to your phone via HIKMICRO Sight.

#### **Before You Start**

Install HIKMICRO Sight on your mobile phone.

#### **Steps**

1. Open HIKMICRO Sight and connect your device to the app. See **App Connection**.
2. Tap **Media** to access device albums.

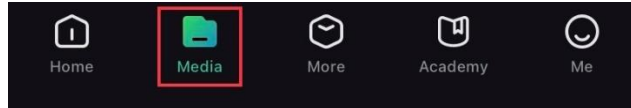

Figure 6-3 Access Device Albums

3. Tap **Local** or **Device** to view the photos and videos.
  - **Local**: You can view the files captured on app.
  - **Device**: You can view the files of the current device.



### Note

The photos or videos may not show in **Device**. Please pull down to refresh the page.

---

4. Tap to select a file, and tap **Download** to export the file to your local phone albums.

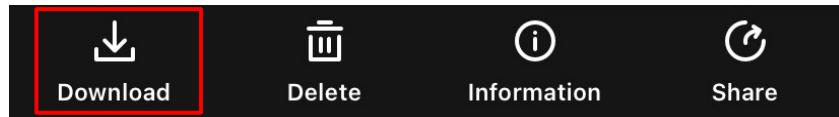

Figure 6-4 Export Files



### Note

- Go to **Me** -> **About** -> **User Manual** on the app to see more detailed operations.
  - You can also access device albums by tapping bottom left icon in the live view interface.
  - The exporting operation may vary due to app updates. Please take the actual app version for reference.
- 





## 6.7.2 Export Files via PC

This function is used to export recorded videos and captured pictures.

### **Before You Start**

Make sure the device is turned on when connecting the cable.

### **Steps**

1. Hold  to show the menu.
2. Go to  **Advanced Settings**, and rotate the wheel to select .
3. Press  to enter the configuration interface.
4. Rotate the wheel to select **USB Flash Drive**.

5. Connect the device and PC with the Type-C cable.



**Note**

Make sure the device is turned on when connecting the cable.

---

6. Open computer disk and select the disk of device. Go to the DCIM folder and find the folder named after the capture year and month. For example, if you capture a picture or record a video on May 2026, go to **DCIM -> 202605** to find the picture or video.

7. Select and copy the files to PC.

8. Disconnect the device from your PC.









**Note**

- The device displays images when you connect it to PC. But functions such as recording and capturing are disabled.
  - When you connect the device to PC for the first time, it installs the drive program automatically.
-

## 7 System Settings







### 7.1 Adjust Date

#### Steps

1. Hold  to show the menu.
2. Go to  **Advanced Settings**, and rotate the wheel to select .
3. Press  to enter the configuration interface.
4. Press  to select the year, month, or day, and rotate the wheel to change the number.
5. Hold  to save settings and exit.

### 7.2 Synchronize Time



#### Steps



1. Hold  to show the menu.
2. Go to  **Advanced Settings**, and rotate the wheel to select .
3. Press  to enter the configuration interface.
4. Rotate the wheel to switch the clock system. 24-hour and 12-hour clock are selectable. If you select 12-hour clock, press , and then rotate the wheel to select **AM** or **PM**.
5. Press  to select the hour or minute, and rotate the wheel to change the number.
6. Hold  to save settings and exit.

### 7.3 Set Language

You can select the device language in this function.

#### Steps





1. Hold  to show the menu.
2. Go to  **Advanced Settings**, and rotate the wheel to select .

3. Press  to enter the configuration interface.
4. Rotate the wheel to select the language as needed, and press  to confirm.
5. Hold  to save settings and exit.

### 7.4 Set Unit

You can switch the unit for distance measurement.





#### **Steps**

1. Hold  to show the menu.
2. Go to  **Advanced Settings**, and rotate the wheel to select .
3. Press  to enter the configuration interface.
4. Rotate the wheel to select the unit as needed.
5. Hold  to save settings and exit.

### 7.5 Cast Device Screen to PC

The device supports casting screen to PC via a UVC protocol-based streaming media player. You can view the device image on the PC display for details.

#### **Steps**







1. Hold  to show the menu.
2. Go to  **Advanced Settings**, and rotate the wheel to select .
3. Press  to enter the configuration interface.
4. Rotate the wheel to select **Digital**.
5. Hold  to save the settings and exit.
6. Open the UVC protocol-based player, and connect your device to the PC via the type-C cable.

## 7.6 Set Screen Lock Passcode



You can set a passcode to lock the device screen to avoid unauthorized access to the device.

### 7.6.1 Enable Passcode

#### Steps

1. Hold  to show the menu.
2. Go to  **Advanced Settings**, and rotate the wheel to select .
3. Press  to enable this function and enter the configuration interface.
4. Press  to switch digit, and rotate the wheel to change the number.
5. Hold  to save settings and exit.

#### Result

When passcode is enabled, you need to enter the passcode when the device is powered on or woken up from standby mode. Press  to switch digit, rotate the wheel to change the number, and hold  to confirm.



#### Note







If you forget the passcode, you can hold  to reset it on the lock screen. This operation requires a factory reset to the device.

---

### 7.6.2 Change Passcode

You can change the passcode as needed when it is enabled.





#### Steps

1. Hold  to show the menu.
2. Go to  **Advanced Settings**, and rotate the wheel to select .
3. Press  and select . Press  again to enter the configuration interface.
4. Press  to switch digit, and rotate the wheel to change the number.

5. Hold  to save settings and exit.

## 7.7 View Device Information





### Steps

1. Hold  to show the menu.
2. Go to  **Advanced Settings**, and rotate the wheel to select .
3. Press  to confirm. You can view the device information such as version, serial No., and available storage space.
4. Hold  to exit.

## 7.8 Restore Device

This function only restores the device basic settings, such as brightness, contrast, and PIP, to their defaults.





### Steps

1. Hold  to show the menu.
2. Go to  **Advanced Settings**, and rotate the wheel to select .
3. Press  to restore the device to defaults according to the prompt.

## 7.9 Reset Device

This function erases all content and settings, including basic settings, storage, passcode, hotspot password, and zeroing.

### Steps

1. Hold  to show the menu.
2. Go to  **Advanced Settings**, and rotate the wheel to select .
3. Press  to restore the device to defaults according to the prompt.

## 8 Frequently Asked Questions

### 8.1 Why is the monitor off?

- Check whether the device is off-battery, in standby mode or **Auto Power Off** is enabled.
- Check the monitor after charging the device for 5 minutes.

### 8.2 The image is not clear, how to adjust it?

Adjust the diopter adjustment ring or focus ring until the image is clear. Refer to *Adjust Diopter* or *Adjust Focus*.

### 8.3 Capturing or recording fails. What's the problem?

Check the following items.

- Whether the device is connected to your PC. Capturing or recording is disabled in this status.
- Whether the storage space is full.
- Whether the device is low-battery.

### 8.4 Why the PC cannot identify the device?

Check the following items.

- Whether the USB connection mode is **USB Flash Drive**.
- Whether the device is connected to your PC with supplied USB cable.
- If you use other USB cables, make sure the cable length is no longer than 1 m.

## Legal Information

©Hangzhou Microimage Software Co., Ltd. All rights reserved.

### About this Manual

The Manual includes instructions for using and managing the Product. Pictures, charts, images and all other information hereinafter are for description and explanation only. The information contained in the Manual is subject to change, without notice, due to firmware updates or other reasons. Please find the latest version of this Manual at the HIKMICRO website ([www.hikmicrotech.com](http://www.hikmicrotech.com)).

Please use this Manual with the guidance and assistance of professionals trained in supporting the Product.

### Trademarks Acknowledgement

 **HIKMICRO** and other HIKMICRO's trademarks and logos are the properties of HIKMICRO in various jurisdictions.

Other trademarks and logos mentioned are the properties of their respective owners.

### Open Source Software Declaration

This product cannot be launched without the contribution of open source software. We respect the Intellectual Property of others, have established and will continue to improve our open source compliance system. You can contact us to get this product's Open Source Software Declaration and Copyleft Source Code.

### LEGAL DISCLAIMER

TO THE MAXIMUM EXTENT PERMITTED BY APPLICABLE LAW, THIS MANUAL AND THE PRODUCT DESCRIBED, WITH ITS HARDWARE, SOFTWARE AND FIRMWARE, ARE PROVIDED "AS IS" AND "WITH ALL FAULTS AND ERRORS". HIKMICRO MAKES NO WARRANTIES, EXPRESS OR IMPLIED, INCLUDING WITHOUT LIMITATION, MERCHANTABILITY, SATISFACTORY QUALITY, OR FITNESS FOR A PARTICULAR PURPOSE. THE USE OF THE PRODUCT BY YOU IS AT YOUR OWN RISK. IN NO EVENT WILL HIKMICRO BE LIABLE TO YOU FOR ANY SPECIAL, CONSEQUENTIAL, INCIDENTAL, OR INDIRECT DAMAGES, INCLUDING, AMONG OTHERS, DAMAGES FOR LOSS OF BUSINESS PROFITS, BUSINESS INTERRUPTION, OR LOSS OF DATA, CORRUPTION OF

SYSTEMS, OR LOSS OF DOCUMENTATION, WHETHER BASED ON BREACH OF CONTRACT, TORT (INCLUDING NEGLIGENCE), PRODUCT LIABILITY, OR OTHERWISE, IN CONNECTION WITH THE USE OF THE PRODUCT, EVEN IF HIKMICRO HAS BEEN ADVISED OF THE POSSIBILITY OF SUCH DAMAGES OR LOSS.

YOU ACKNOWLEDGE THAT THE NATURE OF THE INTERNET PROVIDES FOR INHERENT SECURITY RISKS, AND HIKMICRO SHALL NOT TAKE ANY RESPONSIBILITIES FOR ABNORMAL OPERATION, PRIVACY LEAKAGE OR OTHER DAMAGES RESULTING FROM CYBER-ATTACK, HACKER ATTACK, VIRUS INFECTION, OR OTHER INTERNET SECURITY RISKS; HOWEVER, HIKMICRO WILL PROVIDE TIMELY TECHNICAL SUPPORT IF REQUIRED.

YOU AGREE TO USE THIS PRODUCT IN COMPLIANCE WITH ALL APPLICABLE LAWS, AND YOU ARE SOLELY RESPONSIBLE FOR ENSURING THAT YOUR USE CONFORMS TO THE APPLICABLE LAW. ESPECIALLY, YOU ARE RESPONSIBLE, FOR USING THIS PRODUCT IN A MANNER THAT DOES NOT INFRINGE ON THE RIGHTS OF THIRD PARTIES, INCLUDING WITHOUT LIMITATION, RIGHTS OF PUBLICITY, INTELLECTUAL PROPERTY RIGHTS, OR DATA PROTECTION AND OTHER PRIVACY RIGHTS. YOU SHALL NOT USE THIS PRODUCT FOR ILLEGAL HUNTING ANIMALS, INVASION OF PRIVACY OR ANY OTHER PURPOSE WHICH IS ILLEGAL OR DETRIMENTAL TO THE PUBLIC INTEREST. YOU SHALL NOT USE THIS PRODUCT FOR ANY PROHIBITED END-USES, INCLUDING THE DEVELOPMENT OR PRODUCTION OF WEAPONS OF MASS DESTRUCTION, THE DEVELOPMENT OR PRODUCTION OF CHEMICAL OR BIOLOGICAL WEAPONS, ANY ACTIVITIES IN THE CONTEXT RELATED TO ANY NUCLEAR EXPLOSIVE OR UNSAFE NUCLEAR FUEL-CYCLE, OR IN SUPPORT OF HUMAN RIGHTS ABUSES.

PLEASE FOLLOW ALL THE PROHIBITIONS AND EXCEPTIONAL CAVEATS OF ALL APPLICABLE LAWS AND REGULATIONS, IN PARTICULAR, THE LOCAL FIREARMS AND/OR HUNTING LAWS AND REGULATIONS. PLEASE ALWAYS CHECK NATIONAL PROVISIONS AND REGULATIONS BEFORE PURCHASE OR USE OF THIS PRODUCT. PLEASE NOTE THAT YOU MAY HAVE TO APPLY FOR PERMITS, CERTIFICATES, AND/OR LICENSES BEFORE ANY PURCHASING, SELLING, MARKETING AND/OR USING OF THE PRODUCT. HIKMICRO SHALL NOT BE LIABLE FOR ANY SUCH ILLEGAL OR IMPROPER PURCHASING, SELLING, MARKETING, AND END USES AND ANY SPECIAL, CONSEQUENTIAL, INCIDENTAL, OR INDIRECT DAMAGES ARISING THEREOF.

IN THE EVENT OF ANY CONFLICTS BETWEEN THIS MANUAL AND THE APPLICABLE LAW, THE LATTER PREVAILS.

## Regulatory Information

---

These clauses apply only to the products bearing the corresponding mark or information.

---

### EU Conformity Statement



This product and - if applicable - the supplied accessories too are marked with "CE" and comply therefore with the applicable harmonized European standards listed under the Directive 2014/30/EU (EMCD), Directive 2011/65/EU (RoHS), Directive 2014/53/EU.

Hereby, Hangzhou Microimage Software Co., Ltd. declares that this device (refer to the label) is in compliance with Directive 2014/53/EU.

The full text of the EU declaration of conformity is available at the following internet address:

<https://www.hikmicrotech.com/en/support/download-center/declaration-of-conformity/>

#### **Frequency Bands and Power (for CE)**

The frequency bands and transmitting power (radiated and/or conducted) nominal limits applicable to the following radio equipment are as follows:

Wi-Fi 2.4 GHz (2.4 GHz to 2.4835 GHz), 20 dBm

#### **RF Exposure Information**

This device has been tested and meets applicable limits for Radio Frequency (RF) exposure.

The SAR limit for Europe is 2.0 W/kg (10g) for head, 4.0 W/kg (10g) for Limb-worn. The product has also been tested against this SAR limit.

For the device without a supplied power adapter, use the power adapter provided by a qualified manufacturer. Refer to the product specification for detailed power requirements.

For the device without a supplied battery, use the battery provided by a qualified manufacturer. Refer to the product specification for detailed battery requirements.



Directive 2012/19/EU (WEEE Directive): Products marked with this symbol cannot be disposed of as unsorted municipal waste in the European Union. For proper recycling, return this product to your local supplier upon the purchase of equivalent new equipment, or dispose of it at designated collection points. For more information see: [www.recyclethis.info](http://www.recyclethis.info)



Regulation (EU) 2023/1542 (Battery Regulation): This product contains a battery and it is in conformity with the Regulation (EU) 2023/1542. The battery cannot be disposed of as unsorted municipal waste in the European Union. See the product documentation for specific battery information. The battery is marked with this symbol, which may include lettering to indicate cadmium (Cd), or lead (Pb). For proper recycling, return the battery to your supplier or to a designated collection point. For more information see: [www.recyclethis.info](http://www.recyclethis.info).

### INFORMATIONEN FÜR PRIVATE HAUSHALTE

#### 1. Getrennte Erfassung von Altgeräten:

Elektro- und Elektronikgeräte, die zu Abfall geworden sind, werden als Altgeräte bezeichnet. Besitzer von Altgeräten haben diese einer vom unsortierten Siedlungsabfall getrennten Erfassung zuzuführen. Altgeräte gehören insbesondere nicht in den Hausmüll, sondern in spezielle Sammel- und Rückgabesysteme.

#### 2. Batterien und Akkus sowie Lampen:

Besitzer von Altgeräten haben Altbatterien und Altakkumulatoren, die nicht vom Altgerät umschlossen sind, die zerstörungsfrei aus dem Altgerät entnommen werden können, im Regelfall vor der Abgabe an einer Erfassungsstelle vom Altgerät zu trennen. Dies gilt nicht, soweit Altgeräte einer Vorbereitung zur Wiederverwendung unter Beteiligung eines öffentlich-rechtlichen Entsorgungsträgers zugeführt werden.

#### 3. Möglichkeiten der Rückgabe von Altgeräten:

Besitzer von Altgeräten aus privaten Haushalten können diese bei den Sammelstellen der öffentlich-rechtlichen Entsorgungsträger oder bei den von Herstellern oder Vertriebern im Sinne des ElektroG eingerichteten Rücknahmestellen unentgeltlich abgeben. Rücknahmepflichtig sind Geschäfte mit einer Verkaufsfläche von mindestens 400 m<sup>2</sup> für Elektro- und Elektronikgeräte sowie diejenigen Lebensmittelgeschäfte mit einer Gesamtverkaufsfläche von mindestens 800 m<sup>2</sup>, die mehrmals pro Jahr oder dauerhaft Elektro- und Elektronikgeräte anbieten und auf dem Markt

bereitstellen. Dies gilt auch bei Vertrieb unter Verwendung von Fernkommunikationsmitteln, wenn die Lager- und Versandflächen für Elektro- und Elektronikgeräte mindestens 400 m<sup>2</sup> betragen oder die gesamten Lager- und Versandflächen mindestens 800 m<sup>2</sup> betragen. Vertrieber haben die Rücknahme grundsätzlich durch geeignete Rückgabemöglichkeiten in zumutbarer Entfernung zum jeweiligen Endnutzer zu gewährleisten. Die Möglichkeit der unentgeltlichen Rückgabe eines Altgerätes besteht bei rücknahmepflichtigen Vertriebern unter anderem dann, wenn ein neues gleichartiges Gerät, das im Wesentlichen die gleichen Funktionen erfüllt, an einen Endnutzer abgegeben wird.

#### **4. Datenschutz-Hinweis:**

Altgeräte enthalten häufig sensible personenbezogene Daten. Dies gilt insbesondere für Geräte der Informations- und Telekommunikationstechnik wie Computer und Smartphones. Bitte beachten Sie in Ihrem eigenen Interesse, dass für die Löschung der Daten auf den zu entsorgenden Altgeräten jeder Endnutzer selbst verantwortlich ist.



#### **5. Bedeutung des Symbols „durchgestrichene Mülltonne“:**



Das auf Elektro- und Elektronikgeräten regelmäßig abgebildete Symbol einer durchgestrichenen Mülltonne weist darauf hin, dass das jeweilige Gerät am Ende seiner Lebensdauer getrennt vom unsortierten Siedlungsabfall zu erfassen ist.

## Symbol Conventions

The symbols that may be found in this document are defined as follows.

Symbol	Description
 <b>Note</b>	Provides additional information to emphasize or supplement important points of the main text.
 <b>Caution</b>	Indicates a potentially hazardous situation, which if not avoided, could result in equipment damage, data loss, performance degradation, or unexpected results.
 <b>Danger</b>	Indicates a hazard with a high level of risk, which if not avoided, will result in death or serious injury.

## Safety Instruction

These instructions are intended to ensure that user can use the product correctly to avoid danger or property loss. Please read all the safety information carefully before using.

### Laws and Regulations

Use of the product must be in strict compliance with the local electrical safety regulations.

### Transportation

- Keep the device in original or similar packaging while transporting it.
- Keep all wrappers after unpacking them for future use. In case of any failure occurred, you need to return the device to the factory with the original wrapper.
- Transportation without the original wrapper may result in damage on the device and the company shall not take any responsibilities.
- Do not drop the product or subject it to physical shock. Keep the device away from magnetic interference.

### Power Supply

- If a power adapter is provided in the device package, use the provided adapter only. If no power adapter is provided, ensure the power adapter or other power supply complies with Limited Power Source. Refer to the product label for the power supply output parameters.
- The power delivered by the charger must be between min. 6 Watts required by the radio equipment, and max. 9.5 Watts in order to achieve the maximum charging speed.
- Make sure the plug is properly connected to the power socket.
- DO NOT connect multiple devices to one power adapter, to avoid over-heating or fire hazards caused by overload.

### Battery

- The external rechargeable battery type is 18650, and the battery size should be 19 mm × 70 mm. The rated voltage is 3.635 V, and the battery capacity is 3300 mAh.
- The built-in battery type is rechargeable lithium-ion battery, and the battery size should be 23 mm × 67 mm. The rated voltage is 3.635 V, and the battery capacity is 3350 mAh.
- For long-term storage of the battery, make sure it is fully charged every 3 months to ensure the battery quality. Otherwise, damage may occur.

- CAUTION: Risk of explosion if the battery is replaced by an incorrect type. Replace with the same or equivalent type only.
- Batteries of improper size cannot be installed, and may cause abnormal shutdown.
- Please purchase the batteries recommended by the manufacturer if necessary.
- The purchased batteries by users need to comply with the relevant international standards about battery safety (e.g. EN/IEC standards).
- Make sure the built-in battery temperature is between 0 °C to 45 °C (32 °F to 113 °F) when charging.
- Make sure the external battery temperature is between 0 °C to 55 °C (32 °F to 131 °F) when charging.
- Confirm there is no flammable material within 2 m of the charger during charging.
- DO NOT place the device with battery or the battery alone near heating or fire source. Avoid direct sunlight.
- Improper replacement of the battery with an incorrect type may defeat a safeguard (for example, in the case of some lithium battery types).
- Do not dispose of the battery into fire or a hot oven, or mechanically crush or cut the battery, which may result in an explosion.
- Do not leave the battery in an extremely high temperature surrounding environment, which may result in an explosion or the leakage of flammable liquid or gas.
- Do not subject the battery to extremely low air pressure, which may result in an explosion or the leakage of flammable liquid or gas.
- Dispose of used batteries according to the instructions.
- DO NOT place the battery in the reach of children.
- DO NOT swallow the battery to avoid chemical burns.
- The built-in battery cannot be dismantled. Please contact the manufacture for repair if necessary.
- CAUTION: Risks of short circuit, fire, or explosion if the battery is damaged. Frequent use, dropping, impact, corrosion, or compression of the battery may cause damages including cracked casing, detached plates, or leakage of internal liquid or gas, etc.
- If the battery is damaged, stop using it immediately and dispose of it according to the instructions.
- Maintenance
- If the product does not work properly, please contact your dealer or the nearest service center. We shall not assume any responsibility for problems caused by unauthorized repair or maintenance.
- Make sure that the power has been disconnected before device teardown and repair by professionals.

- If the equipment is used in a manner not specified by the manufacturer, the protection provided by the device may be impaired.
- Check the optical surfaces of objective lens, eyepiece, rangefinder, etc. If necessary, remove dust and sand from the optics using tools and solvent designed especially for this purpose (it is preferable to use a non-contact method).
- Wipe the exterior surfaces of metal, plastic, and silicone parts with a clean and soft cloth. Do not use chemically active substances, solvents, etc. as these may damage the paint.
- Clean the electrical contacts of the battery on the device using a non-greasy organic solvent.
- Using Environment
- Make sure the running environment meets the requirement of the device. The operating temperature shall be -30 °C to 55 °C (-22 °F to 131 °F), and the operating humidity shall be from 5% to 95%.
- DO NOT expose the device to high electromagnetic radiation or dusty environments.
- DO NOT aim the lens at the sun or any other bright light.
- Place the device in a dry and well-ventilated environment.
- Avoid equipment installation on vibratory surface or places subject to shock (neglect may cause equipment damage).
- This equipment is not suitable for use in locations where children are likely to be present.

### **Maintenance**

- If the product does not work properly, please contact your dealer or the nearest service center. We shall not assume any responsibility for problems caused by unauthorized repair or maintenance.
- Make sure that the power has been disconnected before device teardown and repair by professionals.
- If the equipment is used in a manner not specified by the manufacturer, the protection provided by the device may be impaired.
- Check the optical surfaces of objective lens, eyepiece, rangefinder, etc. If necessary, remove dust and sand from the optics using tools and solvent designed especially for this purpose (it is preferable to use a non-contact method).
- Wipe the exterior surfaces of metal, plastic, and silicone parts with a clean and soft cloth. Do not use chemically active substances, solvents, etc. as these may damage the paint.
- Clean the electrical contacts of the battery on the device using a non-greasy organic solvent.

## Using Environment

- Make sure the running environment meets the requirement of the device. The operating temperature shall be -30 °C to 55 °C (-22 °F to 131 °F), and the operating humidity shall be from 5% to 95%.
- DO NOT expose the device to high electromagnetic radiation or dusty environments.
- DO NOT aim the lens at the sun or any other bright light.
- Place the device in a dry and well-ventilated environment.
- Avoid equipment installation on vibratory surface or places subject to shock (neglect may cause equipment damage).
- This equipment is not suitable for use in locations where children are likely to be present.

## Emergency

If smoke, odor, or noise arises from the device, immediately turn off the power, unplug the power cable, and contact the service center.

## Laser



When any laser equipment is in use, make sure that the device lens is not exposed to the laser beam, or it may burn out. The laser radiation emitted from the device can cause eye injuries, burning of skin or inflammable substances. Before enabling the laser ranging function, make sure no human or inflammable substances are in front of the laser lens. Do not place the device where minors can fetch it. According to IEC 60825-1:2014, EN 60825-1:2014+A11:2021, and EN 50689:2021, this laser product is classified as Class 1 laser product and consumer laser product.

## Limited Warranty

Scan the QR code for the product warranty policy.



### **Manufacture Address**

Room 313, Unit B, Building 2, 399 Danfeng Road, Xixing Subdistrict,  
Binjiang District, Hangzhou, Zhejiang 310052, China

Hangzhou Microimage Software Co., Ltd.

COMPLIANCE NOTICE: The thermal series products might be subject to export controls in various countries or regions, including without limitation, the United States, European Union, United Kingdom and/or other member countries of the Wassenaar Arrangement. Please consult your professional legal or compliance expert or local government authorities for any necessary export license requirements if you intend to transfer, export, re-export the thermal series products between different countries.



 Hikmicro Hunting.Global

 Hikmicro Hunting.Global

 HIKMICRO Outdoor

 HIKMICRO Hunting.Global

 [www.hikmicrotech.com](http://www.hikmicrotech.com)

 [support@hikmicrotech.com](mailto:support@hikmicrotech.com)