



# Clamp-on Ultrasonic Flow Meter

User manual

© Hangzhou Microimage Intelligent Control Technology Co., Ltd. All rights reserved.

## About This Manual

The Manual includes instructions for using and managing the Product. Pictures, charts, images and all other information hereinafter are for description and explanation only. The information contained in the Manual is subject to change, without notice, due to firmware updates or other reasons. Please find the latest version of this Manual at the HIKMICRO website (<http://www.hikmicrotech.com>).

Please use this Manual with the guidance and assistance of professionals trained in supporting the Product.

## Trademarks

 **HIKMICRO** and other HIKMICRO's trademarks and logos are the properties of HIKMICRO in various jurisdictions. Other trademarks and logos mentioned are the properties of their respective owners.

## Disclaimer

TO THE MAXIMUM EXTENT PERMITTED BY APPLICABLE LAW, THIS MANUAL AND THE PRODUCT DESCRIBED, WITH ITS HARDWARE, SOFTWARE AND FIRMWARE, ARE PROVIDED "AS IS" AND "WITH ALL FAULTS AND ERRORS". HIKMICRO MAKES NO WARRANTIES, EXPRESS OR IMPLIED, INCLUDING WITHOUT LIMITATION, MERCHANTABILITY, SATISFACTORY QUALITY, OR FITNESS FOR A PARTICULAR PURPOSE. THE USE OF THE PRODUCT BY YOU IS AT YOUR OWN RISK. IN NO EVENT WILL HIKMICRO BE LIABLE TO YOU FOR ANY SPECIAL, CONSEQUENTIAL, INCIDENTAL, OR INDIRECT DAMAGES, INCLUDING, AMONG OTHERS, DAMAGES FOR LOSS OF BUSINESS PROFITS, BUSINESS INTERRUPTION, OR LOSS OF DATA, CORRUPTION OF SYSTEMS, OR LOSS OF DOCUMENTATION, WHETHER BASED ON BREACH OF CONTRACT, TORT (INCLUDING NEGLIGENCE), PRODUCT LIABILITY, OR OTHERWISE, IN CONNECTION WITH THE USE OF THE PRODUCT, EVEN IF HIKMICRO HAS BEEN ADVISED OF THE POSSIBILITY OF SUCH DAMAGES OR LOSS.



YOU ACKNOWLEDGE THAT THE NATURE OF THE INTERNET PROVIDES FOR INHERENT SECURITY RISKS, AND HIKMICRO SHALL NOT TAKE ANY RESPONSIBILITIES FOR ABNORMAL OPERATION, PRIVACY LEAKAGE OR OTHER DAMAGES RESULTING FROM CYBER-ATTACK, HACKER ATTACK, VIRUS INFECTION, OR OTHER INTERNET SECURITY RISKS; HOWEVER, HIKMICRO WILL PROVIDE TIMELY TECHNICAL SUPPORT IF REQUIRED.

YOU AGREE TO USE THIS PRODUCT IN COMPLIANCE WITH ALL APPLICABLE LAWS, AND YOU ARE SOLELY RESPONSIBLE FOR ENSURING THAT YOUR USE CONFORMS TO THE APPLICABLE LAW. ESPECIALLY, YOU ARE RESPONSIBLE, FOR USING THIS PRODUCT IN A MANNER THAT DOES NOT INFRINGE ON THE RIGHTS OF THIRD PARTIES, INCLUDING WITHOUT LIMITATION, RIGHTS OF PUBLICITY, INTELLECTUAL PROPERTY RIGHTS, OR DATA PROTECTION AND OTHER PRIVACY RIGHTS. YOU SHALL NOT USE THIS PRODUCT FOR ANY PROHIBITED END-USES, INCLUDING THE DEVELOPMENT OR PRODUCTION OF WEAPONS OF MASS DESTRUCTION, THE DEVELOPMENT OR PRODUCTION OF CHEMICAL OR BIOLOGICAL WEAPONS, ANY ACTIVITIES IN THE CONTEXT RELATED TO ANY NUCLEAR EXPLOSIVE OR UNSAFE NUCLEAR FUEL-CYCLE, OR IN SUPPORT OF HUMAN RIGHTS ABUSES.

IN THE EVENT OF ANY CONFLICTS BETWEEN THIS MANUAL AND THE APPLICABLE LAW, THE LATTER PREVAILS.

## Symbols

The symbols that may be found in this document are defined as follows.

| Symbol  | Description   |
|---|---|
|  Danger  | Indicates a hazardous situation which, if not avoided, will or could result in serious injury.  |
|  Caution | Indicates a potentially hazardous situation which, if not avoided, could result in equipment damage, data loss, performance degradation, or unexpected results. |
|  Note    | Provides additional information to emphasize or supplement important points of the main text.   |

## Safety Instruction

These instructions are intended to ensure that user can use the product correctly to avoid danger or property loss. The device can only be operated by trained personnel in accordance with these instructions and local safety regulations.

### Laws and Regulations

- The device should be used in compliance with local laws, electrical safety regulations, and fire prevention regulations.

### Transportation

- Keep the device in original or similar packaging while transporting it.
- Do not drop the product or subject it to physical shock. Keep the device away from magnetic interface.

### Electrical Safety

- The device external wiring connected to the hazardous live terminals requires installation by an instructed person.
- Make sure that the power has been disconnected before you wire, install, or disassemble the device.
- The device must be connected to an earthed mains socket-outlet.
- Make sure the plug is properly connected to the power socket.
- If the device is powered by terminals connected to the power cord, ensure correct voltage and wiring of the terminals for connection to mains supply.
- DO NOT expose the device to high electromagnetic radiation.

### Maintenance

- DO NOT maintain the camera when it is powered on, or it may cause electric shock!
- If the product does not work properly, please contact your dealer or the nearest service center. We shall not assume any responsibility for problems caused by unauthorized repair or maintenance.
- Wipe the device gently with a clean cloth and a small quantity of ethanol, if necessary.
- If the equipment is used in a manner not specified by the manufacturer, the protection provided by the device may be impaired.

## Contents

|    |  |    |
|----|--|----|
| 1. | Overview.....  | 1  |
|    | 1.1 Description .....  | 1  |
|    | 1.2 Measuring System.....                                    | 1  |
|    | 1.3 Basics .....   | 1  |
|    | 1.3.1 Time Difference Method .....                           | 2  |
|    | 1.3.2 Doppler Effect Method .....                            | 3  |
| 2. | Electrical Connection .....                                  | 4  |
|    | 2.1 Connection .....   | 4  |
|    | 2.2 Terminal Assignment .....                                | 5  |
|    | 2.3 Cable Requirements .....                                 | 6  |
|    | 2.4 Wiring Instructions .....                                | 6  |
| 3. | Commissioning.....   | 11 |
|    | 3.1 Power On and Self-Check .....                            | 11 |
|    | 3.2 Start-Up Configuration .....                             | 11 |
| 4. | Installation .....   | 14 |
|    | 4.1 Sensor Installation.....                                 | 14 |
|    | 4.1.1 Select Installation Position .....                     | 14 |
|    | 4.1.2 Install the Sensor .....                               | 16 |
|    | 4.2 Transmitter Installation .....                           | 24 |
|    | 4.2.1 Wall Mounting .....                                    | 24 |
|    | 4.2.2 Pipe Mounting .....                                    | 25 |
|    | 4.3 PT1000 Platinum Resistance Installation (Optional) ..... | 27 |
| 5. | Operation.....   | 28 |
|    | 5.1 Display .....  | 28 |
|    | 5.2 Operating Keys.....                                      | 29 |
|    | 5.3 Menu.....  | 29 |
| 6. | Configuration .....  | 30 |
|    | 6.1 Measurement.....   | 30 |
|    | 6.1.1 Sensor Type.....                                       | 30 |

# Clamp-on Ultrasonic Flow Meter • User Manual

---

|   |    |
|---|----|
| 6.1.2 Pipe Parameter .....                | 30 |
| 6.1.3 Medium Parameter .....              | 30 |
| 6.1.4 Traverse .....                      | 31 |
| 6.2 Setup.....                            | 31 |
| 6.2.1 Device ID and Unit.....             | 31 |
| 6.2.2 Totalizer .....                     | 32 |
| 6.2.3 Output Current .....                | 32 |
| 6.2.4 PFS Output .....                    | 33 |
| 6.2.5 Current Input and Switch Input..... | 35 |
| 6.2.6 Low Flow Cut Off .....              | 36 |
| 6.2.7 Measuring Mode.....                 | 37 |
| 6.2.8 Damping .....                       | 37 |
| 6.2.9 Write Protection .....              | 38 |
| 6.3 Display .....                         | 38 |
| 6.3.1 Display Format.....                 | 39 |
| 6.4 Diagnosis.....                        | 39 |
| 6.4.1 Diagnosis Status.....               | 40 |
| 6.4.2 Simulation .....                    | 41 |
| 6.5 Additional Settings .....             | 41 |
| 6.5.1 Date and Time.....                  | 41 |
| 6.5.2 Integration and Communication.....  | 41 |
| 6.5.3 Storage and Reset .....             | 43 |
| 6.6 Calibration .....                     | 43 |
| 6.7 Sensor.....                           | 44 |
| 6.8 About .....                           | 45 |
| 7. Diagnosis Code.....                    | 46 |
| 8. Troubleshooting .....                  | 47 |
| 9. Regulatory Information .....           | 50 |
| 10. Modbus Communication Protocol.....    | 51 |

# 1. Overview

## 1.1 Description

The Clamp-On Ultrasonic Flow Meter is a non-intrusive flow measurement instrument (hereinafter referred to as "device"), useful for measuring the flow of various media in pipes. The sensors of the device are installed externally on the surface of pipes via clamping, avoiding direct contact with the fluid in the pipe. The device is applicable to industrial process control, municipal water supply systems, energy measurement management, etc.

## 1.2 Measuring System

The measuring system of the device includes transmitter, sensor, and the pipe on which the measurement is conducted.

- The sensor is fixed on the outside of the pipe by a holder. It sends and receives ultrasonic signals through the fluid.
- The transmitter controls the measurement data cycle. It eliminates interference signals, analyzes valid signals, and then displays, computes, and outputs the measurement data.

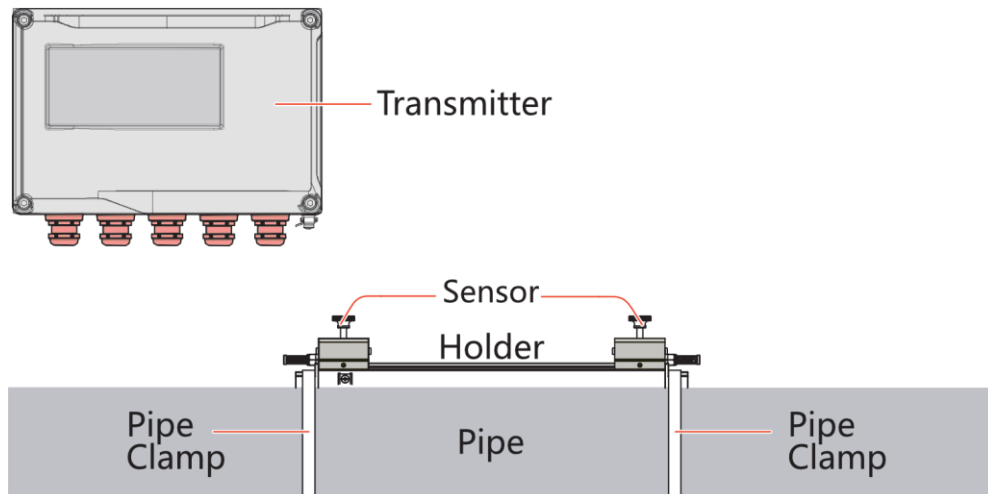

Figure 1-1 Measuring System

## 1.3 Basics

The device automatically switches between the time difference method and the Doppler effect method. In scenarios where the medium is relatively uniform, the time

difference method is used for measurement, while the Doppler effect method is used when the medium contains particles or bubbles.

### 1.3.1 Time Difference Method

The time of flight (TOF) of ultrasonic wave is related to the flow velocity and sound velocity of the medium in the pipe. By testing the flight time, the flow velocity of the medium in the pipe can be obtained, ultimately measuring and calculating the flow.

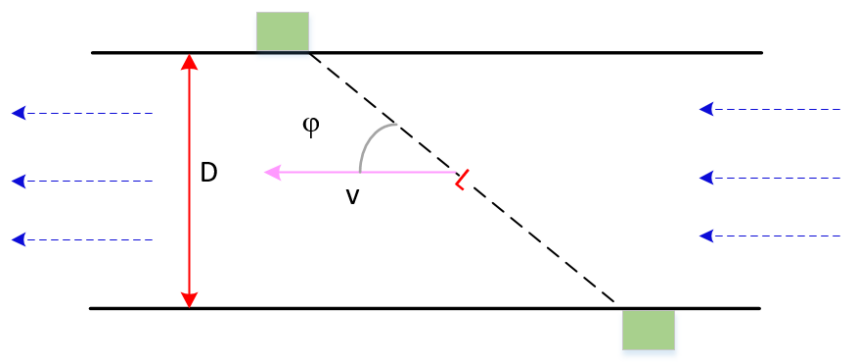

Figure 1-2 Installation of Sensor

Known:

- D = Pipe Diameter
- $\Phi$  = Angle Between Sound Path and Pipe
- $T_{AB}$  = Sound Wave Flight Time From Sensor A to Sensor B
- $T_{BA}$  = Sound Wave Flight Time From Sensor B to Sensor A

Unknown:

- L = Sound Wave Transmission Length
- c = Sound Velocity in Medium
- v = Medium Flow Velocity in Pipe

Sound Wave Transmission Length:

$$L = \frac{D}{\cos\varphi}$$

Sound Wave Flight Time From Sensor A to Sensor B:

$$T_{AB} = \frac{L}{c + v\cos\varphi}$$

Sound Wave Flight Time From Sensor B to Sensor A:

$$T_{BA} = \frac{L}{c - v \cos \varphi}$$

Flow Velocity, Sound Velocity:

$$v = \frac{L}{2 \cos \varphi} \left( \frac{1}{T_{AB}} - \frac{1}{T_{BA}} \right) = \frac{L}{2 \cos \varphi} \left( \frac{T_{BA} - T_{AB}}{T_{AB} T_{BA}} \right) \quad c = \frac{L}{2} \left( \frac{1}{T_{AB}} + \frac{1}{T_{BA}} \right)$$

### 1.3.2 Doppler Effect Method

The Doppler effect method utilizes the Doppler principle in acoustics to detect the frequency offset between the emitted sound wave and the reflected sound wave, which can be used to determine the flow velocity of fluid and then calculate the flow. The actual measurement is the particles velocity in the fluid, which is used to replace the fluid velocity and calculate the flow of fluid.

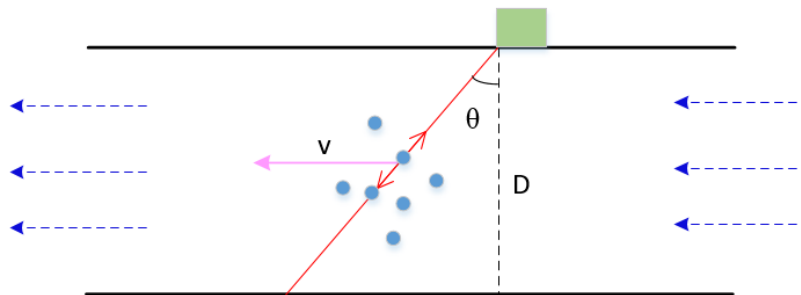

Figure 1-3 Sensor Self-Transmitting and Receiving

The sensor in the emission state emits an ultrasonic pulse with frequency  $f_T$  into the fluid containing particles. Then the sensor switches to the receiving state and receives the signal reflected by the particles. According to the Doppler effect, the frequency of the ultrasonic wave received after being reflected by the particles is  $f_R$ .

When the particle velocity is  $v$ , and the sound velocity is  $c$ , the following relationship exists:

$$f_R = f_T \left( 1 - \frac{v \sin \theta}{c} \right)^2 \approx f_T \left( 1 - \frac{2v \sin \theta}{c} \right)$$

Doppler Frequency Shift:

$$\Delta f = f_T - f_R = f_T \frac{2v \sin \theta}{c}$$

Flow Velocity:

$$v = \frac{c}{2 f_T \sin \theta} \Delta f$$

## 2. Electrical Connection

### 2.1 Connection

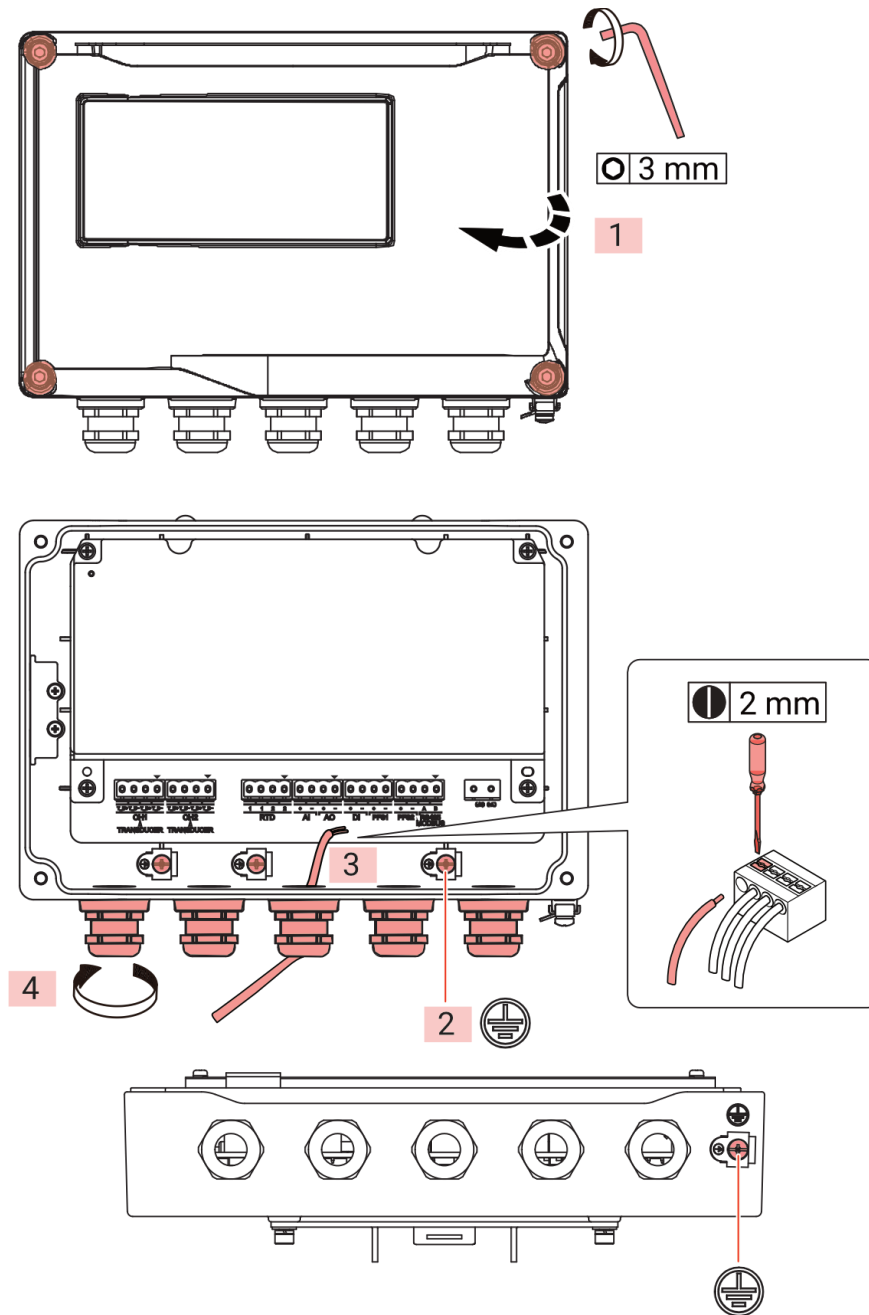

Figure 2-1 Connect the Cable

1. Use a 3 mm hex wrench to loosen the fixing screws and open the front cover of the transmitter.

2. Connect the protective grounding screw.
3. Push the cable through the cable entry and connect the terminal. For details about the terminal, refer to “2.2 Terminal Assignment”.
4. Firmly tighten the cable glands.
  - Hexagon nut installation torque: 3.5 to 4.5 N·m.
  - Sealing nut installation torque: 3.5 to 4.5 N·m.
  - Nut width across flats: 24 mm.

**⚠ Caution**

Tighten the grounding screws on the transmitter using the cross screwdriver. Make sure that the transmitter is grounded, either by connecting it to the pipe ground or the AC power ground.

## 2.2 Terminal Assignment

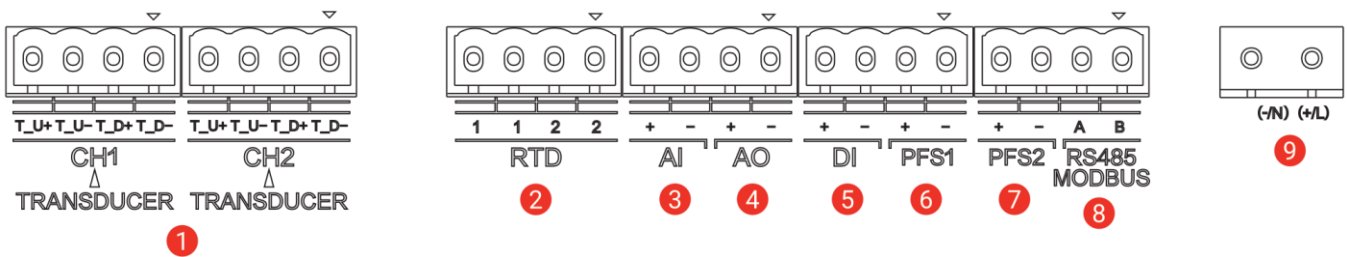

Figure 2-2 Transmitter Terminal

Table 2-1 Terminal Assignment

| No.   | Description  |
|-------|--|
| 1     | Sensor interface.  |
| 2     | PT1000 platinum resistance interface.                                |
| 3     | 4 to 20 mA current input, active.                                    |
| 4     | 4 to 20 mA current output, active/passive.                           |
| 5     | Switch input, active.  |
| 6 & 7 | Two sets of pulse (P), frequency (F), or switch (S) output, passive. |
| 8     | Modbus communication, RS-485 interface.                              |
| 9     | Power supply input, 12 to 36 VDC or 100 to 240 VAC.                  |

## 2.3 Cable Requirements

The connecting cable prepared separately should meet the following requirements.

Table 2-2 Signal Cable Requirements

| Cable        | Requirements   |
|--------------|--|
| Signal Cable | <p>Signal cable refers to the current input/output, switch input, PFS output, and RS-485 cables.</p> <p>The outer diameter of signal cables should be between 6 and 12 mm.</p> <p>Use an anti-interference RVVP cable to reduce the impact of external electromagnetic interference on measurements.</p> |

Table 2-3 Power Cable Requirements

| Cable                     | Conductor Cross-Section      | Cable Length (max.)     | Outer Diameter |
|---------------------------|------------------------------|-------------------------|----------------|
| Power Cable<br>12 VDC/5 A | 1 mm <sup>2</sup> (18 AWG)   | 5 m                     | 6.5 to 8 mm    |
|                           | 2.5 mm <sup>2</sup> (14 AWG) | 20 m                    |                |
| Power Cable<br>24 VDC/5 A | 1 mm <sup>2</sup> (18 AWG)   | 100 m                   |                |
|                           | 2.5 mm <sup>2</sup> (14 AWG) | 250 m                   |                |
| Power Cable<br>VAC        | No Special Requirements      | No Special Requirements |                |

## 2.4 Wiring Instructions

### Sensor Connection

Connects the sensor to the transmitter.

- “T\_U” stands for upstream sensor connector, and “T\_D” stands for downstream sensor connector.
- Connect green cable to “T\_U+” or “T\_D+”, yellow cable to “T\_U-” or “T\_D-”, and black cable to transmitter grounding screw.

#### Note

It is recommended to connect the grounding screw first and then connect the cable to the sensor terminal.

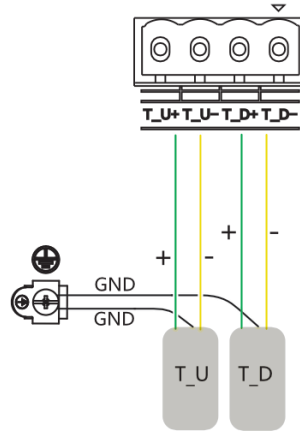

Figure 2-3 Sensor Connection

## Power Supply Connection

- AC power supply: connect live wire to “L”, neutral wire to “N”, and ground wire to transmitter grounding screw.
- DC power supply: connect positive terminal wire to “+” and negative terminal wire to “-”.

## PT1000 Platinum Resistance Connection

Connect the optional PT1000 for standard temperature value input.

Connect two red cables to “1”, and two white cables to “2”.

### Note

For instructions of PT1000 installation, refer to “4.3 PT1000 Platinum Resistance Installation (Optional)”.

## Active 4 to 20 mA Input

For medium parameter (e.g., temperature) input.

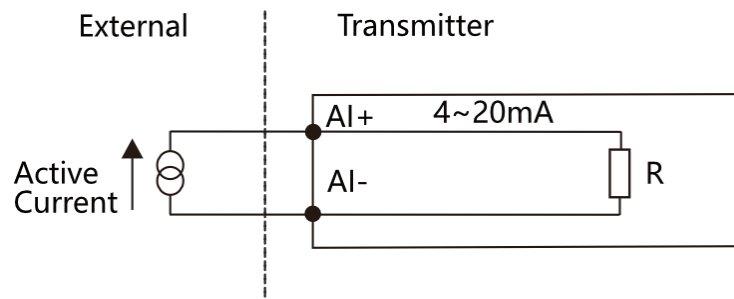

Figure 2-4 Active Current Input

### Active 4 to 20 mA Output

For analog output to PLC, DCS, etc.

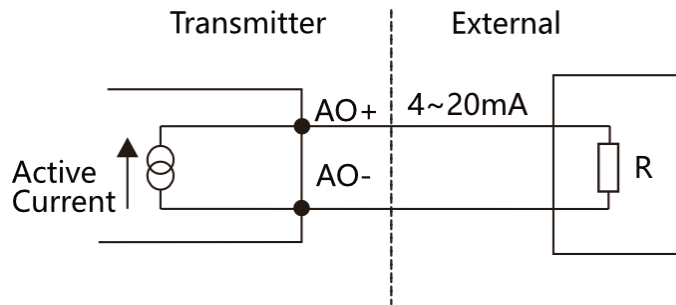

Figure 2-5 Active Current Output

### Passive 4 to 20 mA Output

For analog output to PLC, DCS, etc.

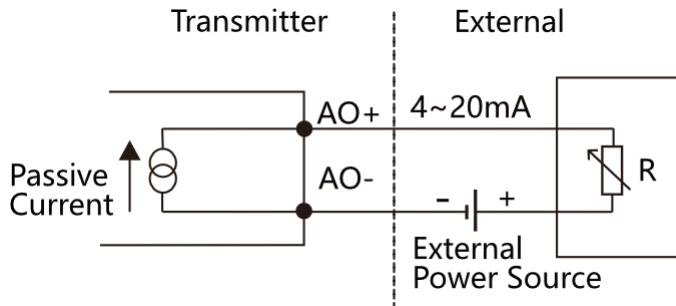

Figure 2-6 Passive Current Output

### Active Switch Input

For device control (e.g., totalizer reset) via digital input signal.

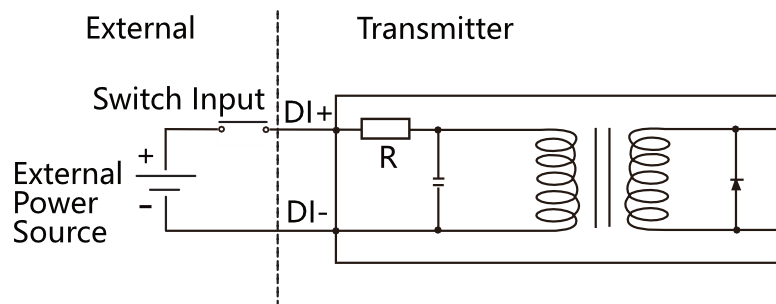

Figure 2-7 Active Switch Input

### Passive Pulse/Frequency/Switch Output

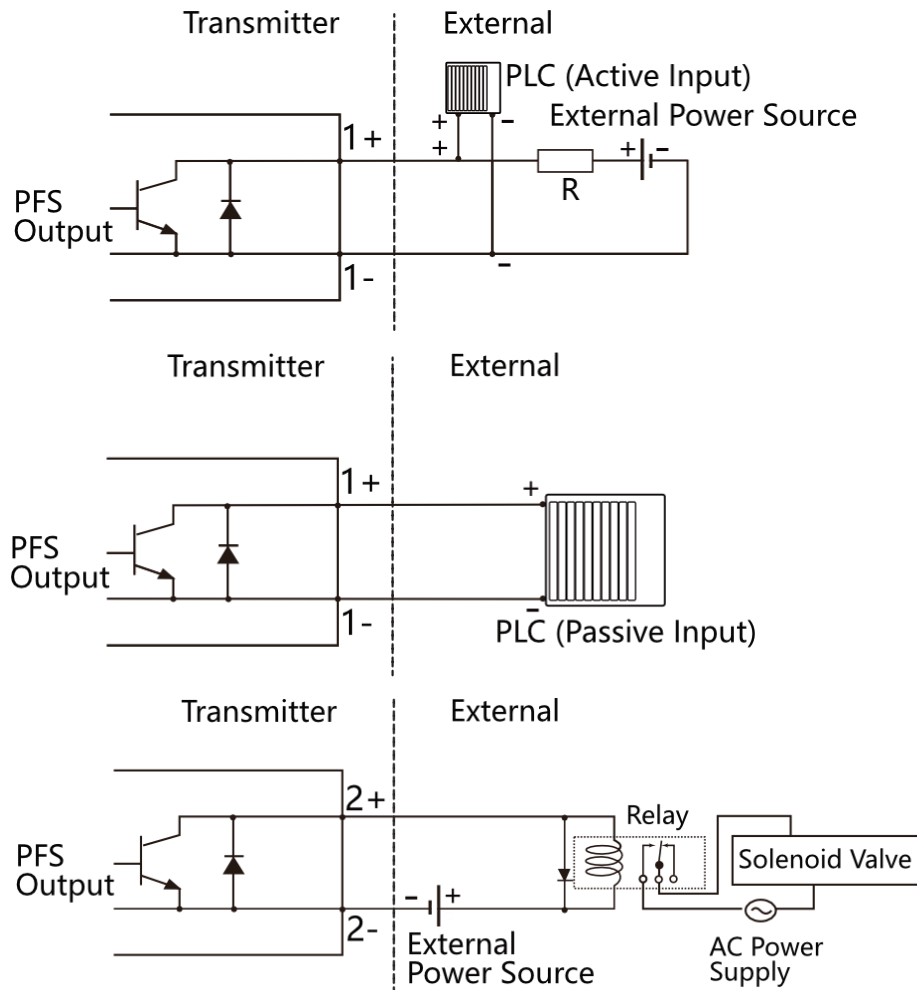

Figure 2-8 Passive Pulse/Frequency/Switch Output

### Modbus Communication

For device remote configuration via Modbus communication.

Connect A (485+) wire to "A" and B (485-) wire to "B". Please purchase a RS-485 to USB converter separately for PC connection.

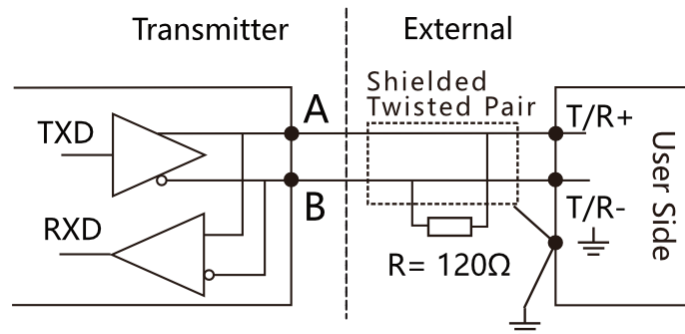

Figure 2-9 Modbus Communication

 **Note**

- All signal terminals, including current input and output, switch input, PFS output, and RS-485 interfaces, are 4pin terminals.
- For detailed information and configuration of signal input and output, refer to “6.2 Setup”.

## 3. Commissioning

Before commissioning the device, perform self-check and set basic measurement parameters according to actual conditions.

 **Note**

The illustrations and instructions in this manual are for reference only. Actual devices may vary according to different hardware versions.

### 3.1 Power On and Self-Check

 **Note**

- Connect the cables when the device is powered off. Make sure all connections are correct, including power supply, signal input and output, sensor, etc.
- Make sure that the input voltage and current meet the device requirements, refer to the technical specifications of the device.

After the device is powered on, it will automatically start up and perform hardware and connection check.

Table 3-1 Device Self-Check

| Status   | Solution   |
|--|--|
| The screen displays information normally with green backlight and the buttons work properly. | Operates normally.   |
| The background of the screen is red and a diagnostic code pops up.                           | Self-check failed. Refer to “7 Diagnosis Code” and “8 Troubleshooting” for instructions. |

























### 3.2 Start-Up Configuration

After the initial start-up of the device, set the measurement parameters according to the prompts, including pipe parameters, medium parameters, sensor spacing, etc.

 **Note**

Set the parameters based on sensor installation and pipe condition.

Table 3-2 Start-Up Configuration

| No. | Step                       | Description   |
|-----|----------------------------|---|
| 1   | Select language.           | Default: English.   |
| 2   | Select sensor type.        | Press  or  to select the sensor type, and press  to confirm.   |
| 3   | Set pipe parameter.        | <ol style="list-style-type: none"> <li>Press  to set the outer diameter, wall thickness, and roughness of the pipe, press  to switch to the next digit, and press  to confirm.</li> <li>Press  or  to select pipe material, and press  to confirm. The material can be customized, and you can set the transverse wave and longitudinal wave.</li> </ol>   |
| 4   | Set medium parameter.      | <ol style="list-style-type: none"> <li>Press  or  to select the medium type, and press  to confirm.</li> <li>Press  or  to select the medium temperature source, and press  to confirm. You can customize the medium temperature value or use the temperature value from an external temperature sensor.</li> <li>Press  to set the medium density, press  to switch to the next digit, and press  to confirm.</li> </ol> |
| 5   | Select number of traverse. | <p>Press  or  to select the number of traverse, and press  to confirm.</p> <p>The number of traverse is determined by pipe diameter, etc. Refer to "6.1.4 Traverse".</p>   |
| 6   | Set display parameter.     | Press  or  to select the measurement value to show in the display area, and press  to confirm. Supports cyclic display through four kinds of measurement values.   |
| 7   | Set and install sensor.    | <ol style="list-style-type: none"> <li>Confirm the sensor recommended distance. The transmitter will automatically output the recommended spacing for sensors based on the pipe, medium, etc.</li> <li>Install the sensors according to the recommended distance, and check the SNR (signal-to-noise ratio) of the installation position.</li> </ol> <p> <b>Note</b><br/>The higher the SNR is, the higher the measurement accuracy</p>  |

|  |  |   |
|--|--|---|
|  |  | <p>will be.</p> <p>If the SNR is higher than 24%, the signal quality of the installation position meets the requirements. If the SNR is lower than 24%, the signal quality is poor and it is recommended to check the pipe condition or adjust the sensor distance.</p> <p>In actual use, the SNR should be stably above 60% to ensure the detection stability.</p> <p>Refer to "6.7 Sensor" for details.</p> |
|--|--|---|

### **Operating Result:**

After the start-up configuration is completed, the device will prompt that the configuration is finished and return to the display area.

## 4. Installation

---

 **Caution**

- Leave enough space around the installation point for maintenance and repair.
  - Do not install the device in places that are prone to lightning strikes or waterlogging/rainfall. Avoid installing it in hot, direct sunlight, and corrosive environments.
  - Select a place with no vibration or minor vibration.
- 

### 4.1 Sensor Installation

Install the sensor on the same side or opposite side of the pipe point according to the actual site conditions by using different tools and accessories.

#### 4.1.1 Select Installation Position

Correctly select the installation position of the sensor to ensure that sound signals are received and analyzed in optimal conditions for accurate and reliable measurement results.

#### Maintain Pipe Status

Before actual installation, check and maintain the pipes to meet the measurement requirements as follows:

- The pipes should be welded before the devices are in place and no electric welding operation is allowed after the devices are in place. When other welding operations are needed on the pipes after the devices are installed, the power of devices should be cut off first.
- Clean rust, paint, and other sundries on the pipe before installing the sensor.
- Do not select points near deformed or damaged pipes or welds.

#### Upstream and Downstream Straight Pipe Length Meets Requirements

The upstream of the sensor shall have a uniform straight pipe section of at least 10D (D: inner diameter of the pipe), and the downstream shall have at least 5D, with none of any valves, elbows, reducers, etc. The installation points should be sufficiently far away from interference sources such as valves and pumps.

When there are flow-disturbing components (such as partially open valves, control valves, globe valves, etc.) in upstream, the straight tube length should be increased.

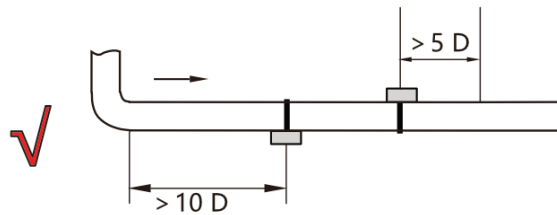

Figure 4-1 Upstream and Downstream Straight Pipe Length Requirements

### Avoid Installation Position Where Impurities Tend to Accumulate

Gas accumulation and solid precipitation adhesion in the measuring tube will increase the measurement error.

Install the sensor on the pipe segment with flow direction from bottom to top, and avoid the following positions:

- Avoid the highest point of the pipe, where gas is likely to accumulate.
- Do not install the sensor above a downwardly drained pipe, as it may cause the pipe to be not full of fluid.

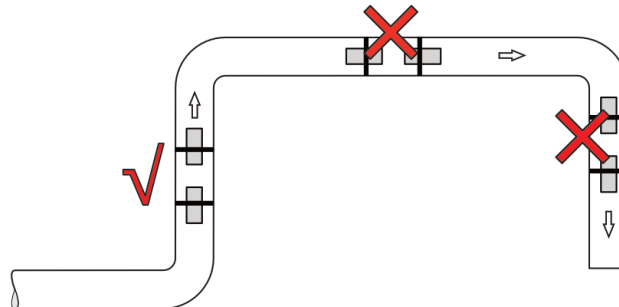

Figure 4-2 Avoid Accumulated Impurities

### Make Sure the Pipe Is Full

If the fluid is not full in the pipe, it may cause measurement error of the device. Therefore, the sensor should be installed on the section where the pipe is full of fluid.

Install the sensor on the pipe segment with flow direction from bottom to top or on the outlet of the elevated downstream pipe segment.

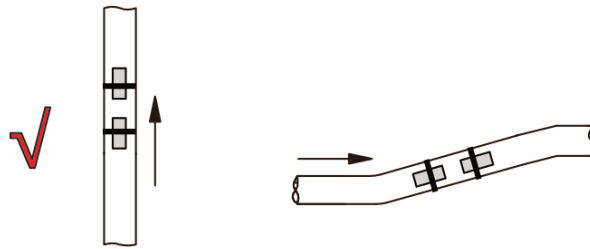

Figure 4-3 Full Pipe Position

### Installation on the Side of Horizontal Pipe

When installing the sensor on a horizontal pipe, it is recommended to install the sensor horizontally on the side of the pipe so that the sound wave can travel horizontally in the pipe. This will avoid solid precipitation at the bottom of the pipe or bubbles on the upper side of the pipe from affecting signal transmission.

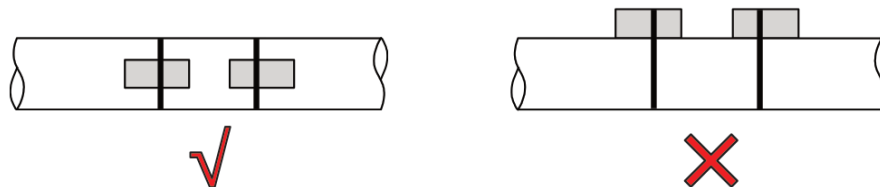

Figure 4-4 Installation on the Side of Horizontal Pipe

### 4.1.2 Install the Sensor

When installing sensors in pipes, there are two common ways: same-side mounting and opposite-side mounting.

When the inner diameter of the pipe is no more than 300 mm, it is recommended to install on the same side; when the inner diameter of the pipe is more than 300 mm, please install on the opposite side.

- Same-Side Mounting

The sensors are installed on the same side of the pipe.

Compared with the installation on the opposite side, the flow velocity and sound velocity range are smaller. The sound beam traverses the pipe in 2 orientations, and this method has higher measurement precision. As the number of sound paths increases, the measurement precision rises.

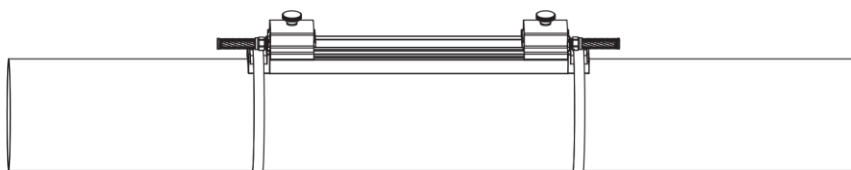

Figure 4-5 Same-Side Mounting (Reflective)

## ● Opposite-Side Mounting

The sensors are mounted on the opposite side of the pipe.

Compared with the installation on the same side, the flow velocity and sound velocity are larger. It is recommended to use this way when precipitation occurs on the inner wall of the pipe or in media with high acoustic damping.

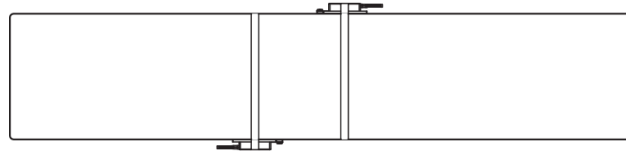

Figure 4-6 Opposite-Side Mounting (Transmissive)

## Same-Side Mounting

Use the supplied holder to install the sensors on one side of the pipe.



### Caution

For non-magnetic pipes, use tape or other materials to fix the holder first to prevent them from falling off.

---

1. Place the holder above the pipe and ensure that the holder is located as follows:
  - The upstream straight pipe length shall be at least 10D (D: pipe inner diameter), and the downstream shall be at least 5D.
  - The flow direction of the medium should be consistent with the direction of the holder arrow.

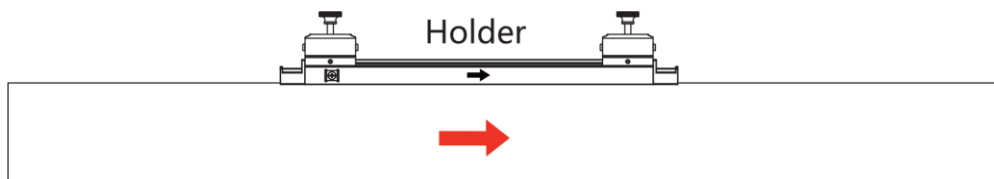

Figure 4-7 Place the Holder

2. Mount the pipe clamp and use a cross/flat-blade screwdriver or an adjustable wrench to pre-tighten it to secure the holder. Be careful not to let the holder fall off during installation.

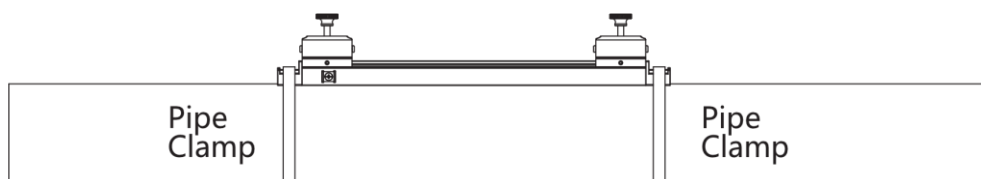

Figure 4-8 Pre-Tighten the Holder

3. Rotate the holder 90 degrees around the pipe to make it parallel with the pipe, and use a cross/flat-blade screwdriver or an adjustable wrench to tighten the pipe clamp.

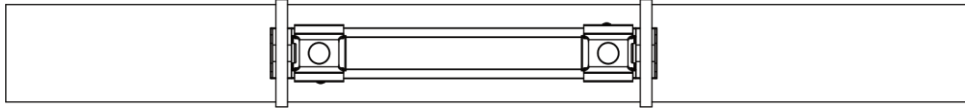

Figure 4-9 Rotate the Holder

4. Apply coupling agent to the upstream sensor and place it on the top of the holder.



### Caution

Make sure the coupling agent is uniform to prevent possible air gap from affecting the measurement.

---

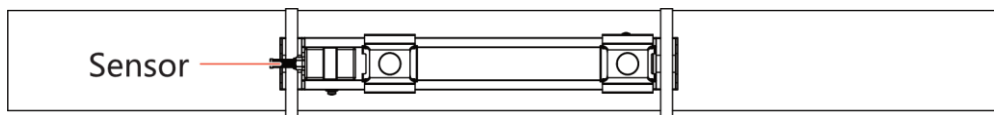

Figure 4-10 Place the Upstream Sensor

5. Move the holder vise directly above the sensor and tighten the hand nut to secure the sensor.

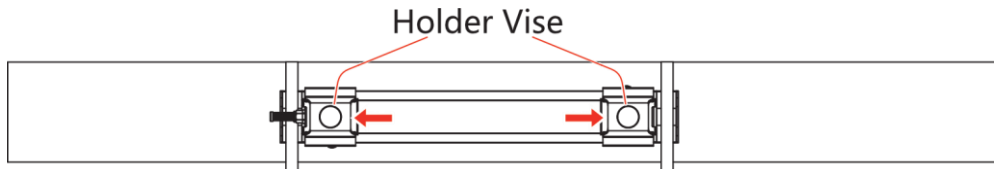

Figure 4-11 Secure the Upstream Sensor

6. Repeat Step 4 to 5 to install and fix the downstream sensor according to the recommended distance between sensors calculated by the transmitter.

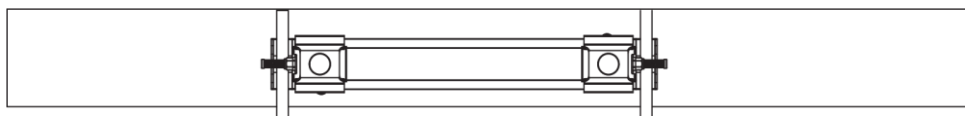

Figure 4-12 Install the Downstream Sensor



### Note

For recommended sensor spacing, refer to step seven of “3.2 Start-Up Configuration” or “6.7 Sensor”.

## Opposite-Side Mounting (Mylar Sheet)

Use the mylar sheet and other accessories to install the sensor on the opposite side of the pipe via the pipe clamp.

 **Note**

Please prepare tools such as the ruler, tape measure, marker pen, and screwdriver separately, or contact our technical support for assistance.

1. Preparation: Observe and determine the flow direction of the medium, grind pipes and remove rust, etc.
2. Wrap the mylar sheet around the pipe and overlap the ends. Remove the backing film and stick them together.

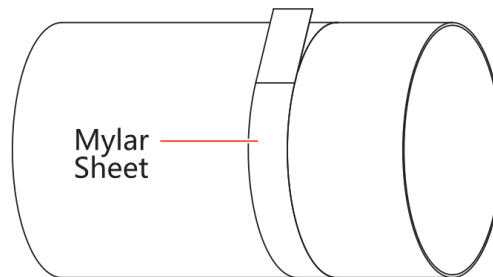

Figure 4-13 Wrapping the Mylar Sheet

3. Mark points A and B.

- 1) Use a marker pen to draw a start line along the edge of the mylar sheet.
- 2) Use a tape measure to wrap around the edge of the mylar sheet and measure the circumference of the pipe. Mark points A and B at half the circumference.

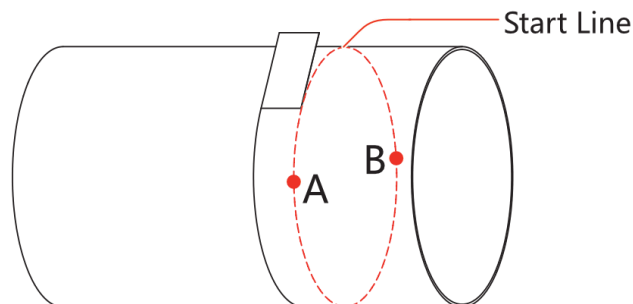

Figure 4-14 Mark Points A and B

4. Mark point C.

- 1) Use a ruler to draw a horizontal line from point A perpendicular to the start line and coinciding with the mylar sheet.
- 2) Mark point C according to the recommended distance between sensors calculated by the transmitter.
- 3) Draw an end line from point C perpendicular to the horizontal line.

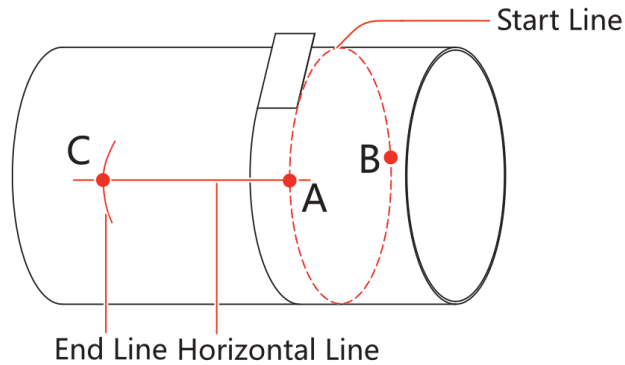

Figure 4-15 Mark Point C

 **Note**

For recommended sensor spacing, refer to step seven of “3.2 Start-Up Configuration” or “6.7 Sensor”.

5. Apply coupling agent to the first sensor and place it at point B. Use a cross/flat-blade screwdriver or an adjustable wrench to tighten the pipe clamp to fix the sensor.

---

 **Caution**

Make sure the coupling agent is uniform to prevent possible air gap from affecting the measurement.

---

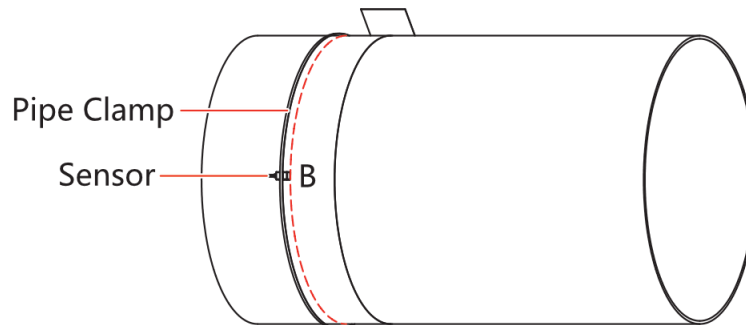

Figure 4-16 Fix Sensor at Point B

6. Fix sensor at point C.
  - 1) Apply coupling agent to the second sensor and place it at point C.
  - 2) Fine-tune the sensor horizontally and vertically to find the location with the maximum signal-to-noise ratio.
  - 3) Use a cross/flat-blade screwdriver or an adjustable wrench to tighten the pipe clamp.

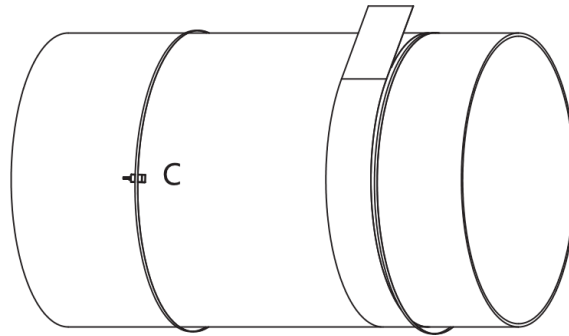

Figure 4-17 Fix Sensor at Point C

## Opposite-Side Mounting (Wire Clamp)

Install the sensor on the opposite side of the pipe using a wire clamp and other accessories.

### Note

Please contact our technical support to get the wire clamp and help with the installation.

1. Calculate the length (L) of the wire rope and bend the rope to mark at the calculated length according to the actual situation.

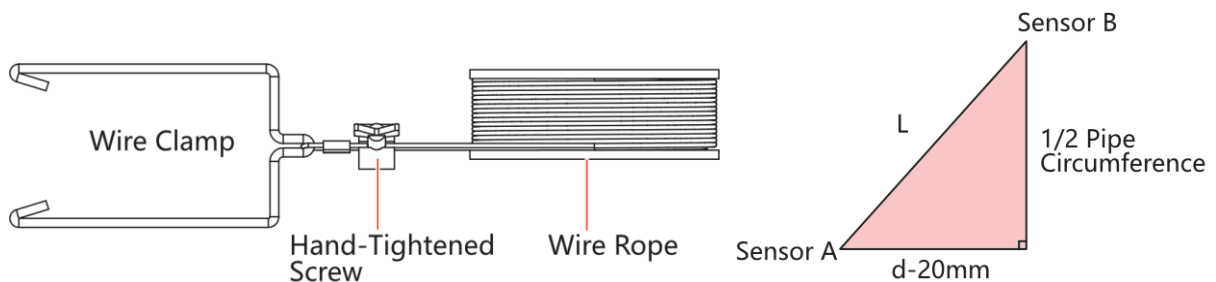

Figure 4-18 Wire Clamp and Wire Rope Length Calculation

### Note

“d” represents the recommended installation spacing between transmitters, refer to step seven of “3.2 Start-Up Configuration” or “6.7 Sensor”.

2. Install the first pipe clamp at an appropriate location.

Leave a gap of sensor height between the pipe clamp and the pipe wall. Install the clamp buckle above the sensor, with the screw holes facing up so that you can use a screwdriver to tighten the buckle.

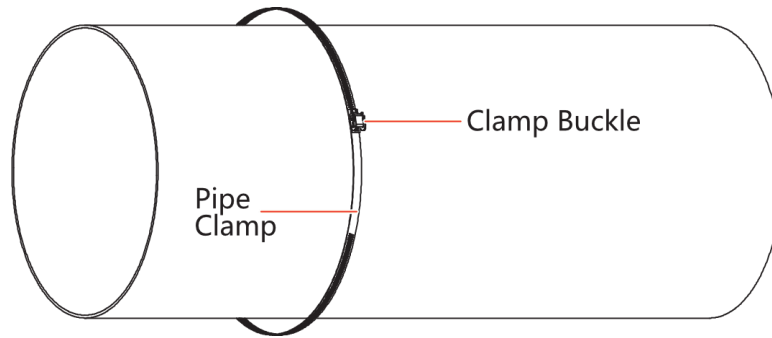

Figure 4-19 Pre-Tighten the Pipe Clamp

3. Apply coupling agent on the sensor center.

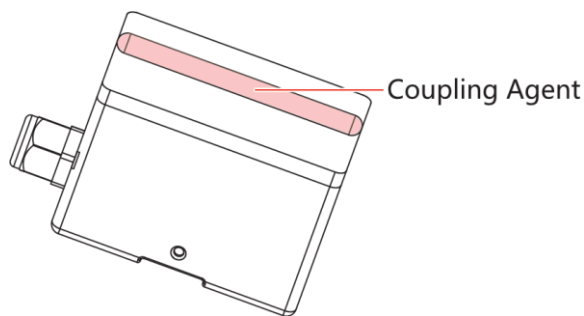

Figure 4-20 Apply Coupling Agent

4. Install the first sensor with the pipe clamp and fix the pipe clamp in the groove of the sensor. Use a cross/flat-blade screwdriver or an adjustable wrench to tighten the clamp buckle from top to bottom

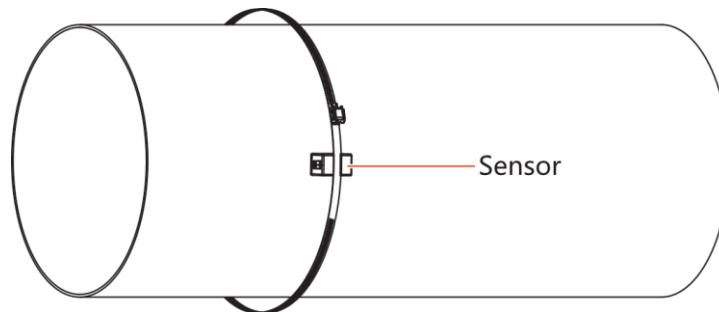

Figure 4-21 Install the First Sensor

5. Determine the second sensor's installation position.
  - 1) Put the wire clamp on the sensor, and let the wire ropes converge at the back of the pipe from both sides.
  - 2) At the wire rope bend marked in Step 1, secure the hand-tightened screw of the wire clamp and bring the two wire ropes together.

- 3) Tighten the two wire ropes to be of the same tension, and use a marker pen to draw a vertical red mark at the intersection of the two ropes, which is the second sensor installation position.

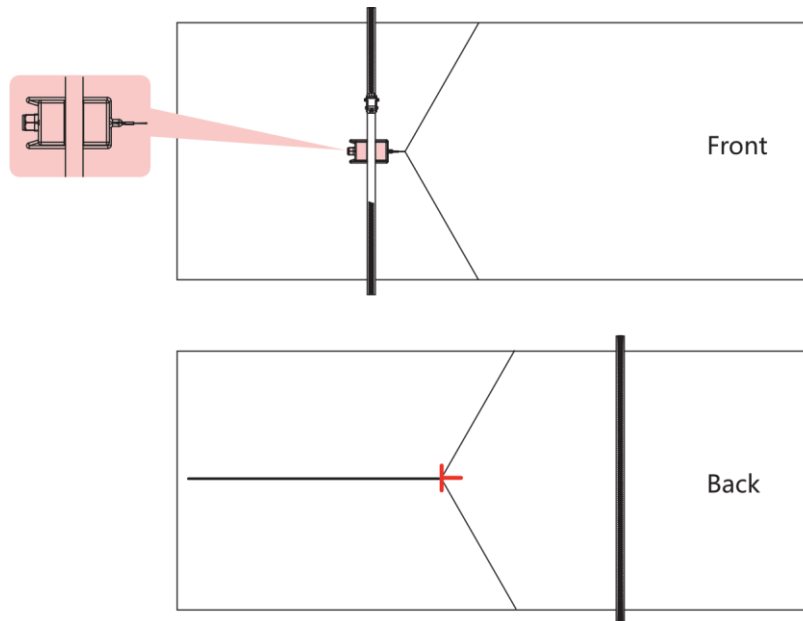

Figure 4-22 Locate the Second Sensor

6. Pre-tighten the second pipe clamp about 20 mm to the left of the vertical red mark.

Leave a gap of sensor height between the pipe clamp and the pipe wall. Install the clamp buckle above the sensor, with the screw holes facing up so that you can use a screwdriver to tighten the buckle.

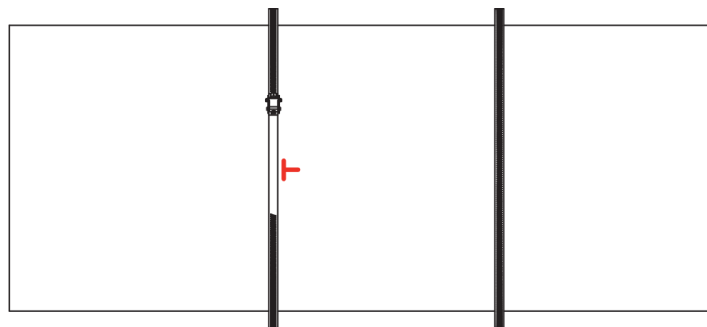

Figure 4-23 Tighten the Second Pipe Clamp

7. Apply coupling agent on the second sensor.
8. Install the second sensor.
  - 1) Insert the sensor into the pipe clamp and align it with the vertical red mark. Secure the pipe clamp onto the sensor's groove, press the sensor tightly against the pipe wall, and observe the signal-to-noise ratio feedback from the transmitter. Ensure the point signal-to-noise ratio is greater than 24%.

- 2) Use a cross/flat-blade screwdriver or an adjustable wrench to tighten the clamp buckle from top to bottom.

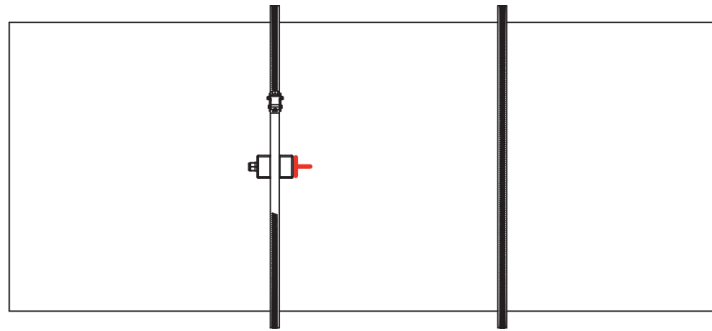

Figure 4-24 Install the Second Sensor

## 4.2 Transmitter Installation

### 4.2.1 Wall Mounting

1. Align four M4 screws to the screw holes of the transmitter, and fix the standard back panel bracket on the back of the transmitter with a 3 mm hex wrench.

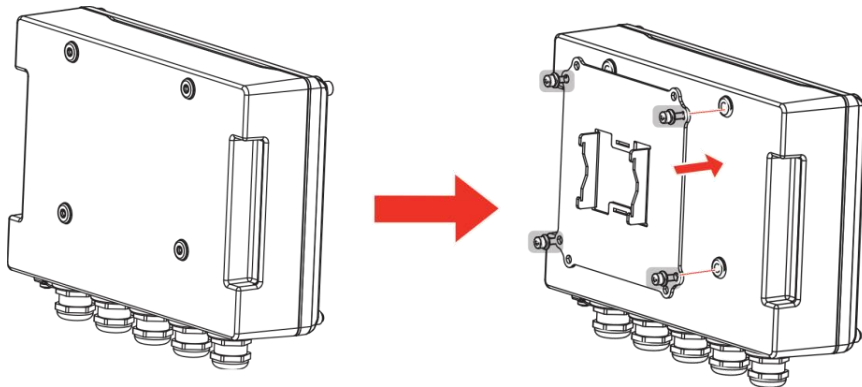

Figure 4-25 Install the Back Panel Bracket

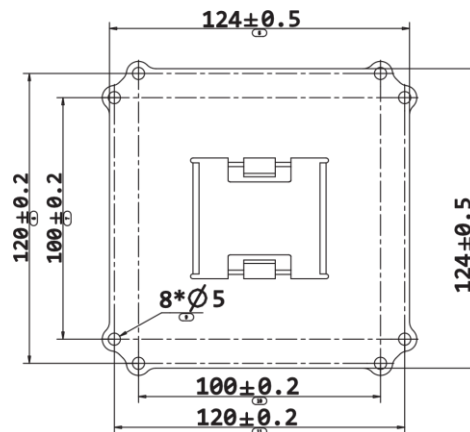

Figure 4-26 Back Panel Bracket Dimension (Unit: mm)

2. Install the purchased national standard guide rail (specification requirement: DIN35, thickness 1.2 mm) into the bracket's slot, and push the transmitter into the guide rail from both sides.

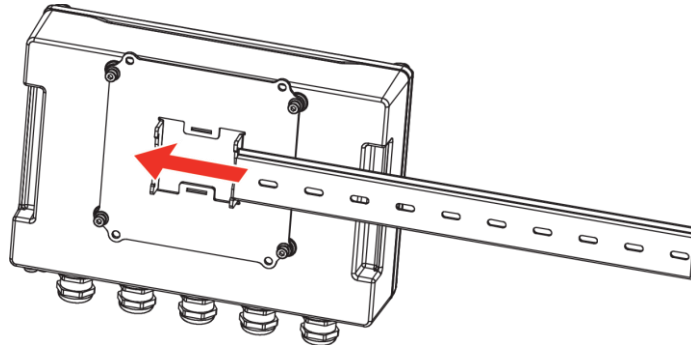

Figure 4-27 Install the Guide Rail

3. Install the guide rail on the wall, power distribution box, etc.

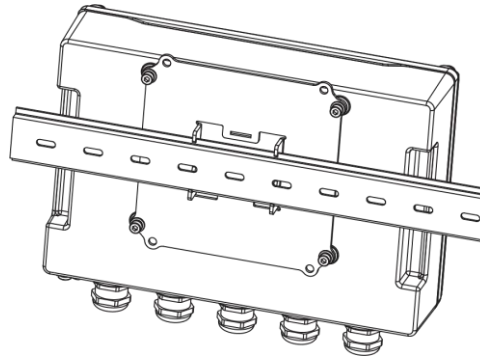

Figure 4-28 Fix the Guide Rails

### 4.2.2 Pipe Mounting

---

 **Caution**

The pipe should be stable enough to bear the pressure generated by the transmitter and the force of the clamps.

---

1. Align four M4 screws to the screw holes of the transmitter, and fix the standard back panel bracket on the back of the transmitter with a 3 mm hex wrench.

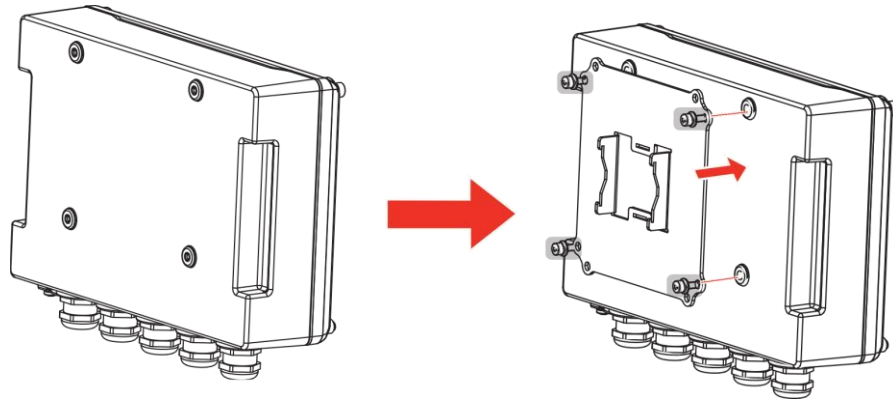

Figure 4-29 Install the Back Panel Bracket

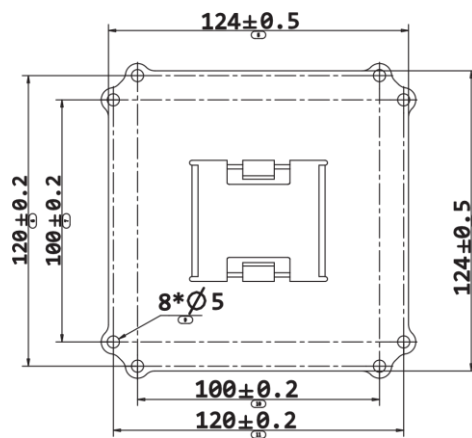

Figure 4-30 Back Panel Bracket Dimension (Unit: mm)

2. Prepare the purchased pipe clamp (recommended specification within DN100, i.e., the nominal diameter of the pipe is less than 100 mm), and thread the pipe clamp through the hole in the transmitter bracket.

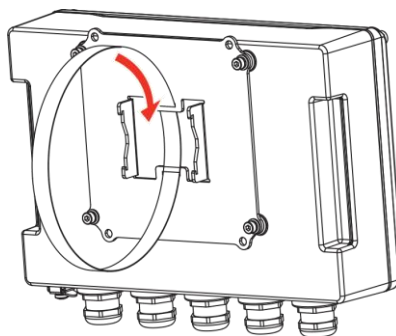

Figure 4-31 Thread the Pipe Clamp

3. Lock the pipe clamp to fix the transmitter to the pipe.

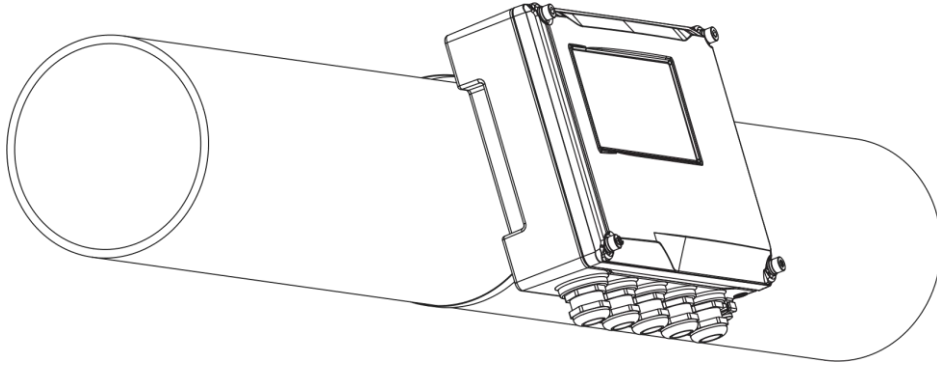

Figure 4-32 Fix the Transmitter

### 4.3 PT1000 Platinum Resistance Installation (Optional)

1. Pre-tighten the first pipe clamp at an appropriate position.

Leave a gap of PT1000 height between the pipe clamp and the pipe wall. Install the clamp buckle above the PT1000, with the screw holes facing up so that you can use a screwdriver to tighten the buckle.

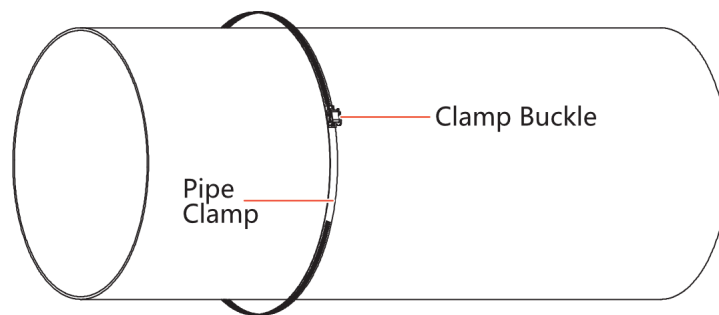

Figure 4-33 Pre-Tighten the Pipe Clamp

2. Install the PT1000 with the pipe clamp and fix the pipe clamp in the groove of the PT1000. Use a cross/flat-blade screwdriver or an adjustable wrench to tighten the clamp buckle from top to bottom.

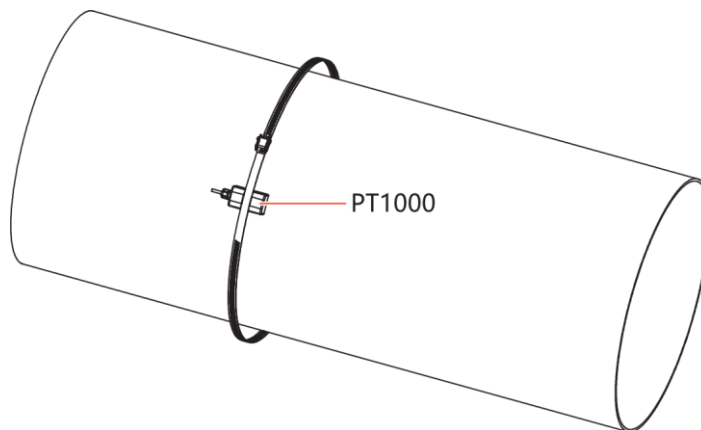

Figure 4-34 Install the PT1000

## 5. Operation

### 5.1 Display

After the flow meter is powered on, the display area will appear on the screen. You can press keys to adjust the settings.

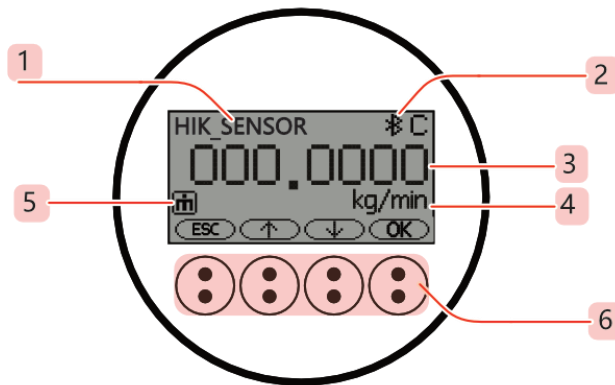







Figure 5-1 Display Area

Table 5-1 Display Area Icon Description







| Icon Name            | Description  |   |   |
|----------------------|--|---|---|
| 1: Device ID         | The unique serial No. of the device.   |   |   |
| 2: Status Bar        | :<br><b>Write Protection On</b><br>Write Protection is used to protect and limit device access.  | :<br><b>Bluetooth On</b><br>Bluetooth is for data communication between the device and the mobile client App. | :<br><b>CFMS:</b><br><b>Diagnosis Status</b><br>Device supports self-diagnosis and displays a corresponding status symbol when in an abnormal status. |
| 3: Measurement Value | Measurement readings. Cyclically shows four measurement values, and variable and style of the display measurement values can be switched . |   |   |
| 4: Measurement Unit  | Unit of the measurement value. The unit can be switched.   |   |   |
| 5: Measurement       | Variable of the measurement value.   |   |   |

|                   |  |
|-------------------|--|
| Icon              |  : Mass Flow;  : Volume Flow;  : Flow Rate.<br>   represents three different types of totalizers. |
| 6: Operating Keys | For function settings.   |

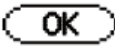

## 5.2 Operating Keys

The key types may vary according to different menu functions. Refer to actual interface for details.

Table 5-2 Key Description

| Key Type  | Display Area Interface                       | Menu Interface                         |
|---|--|--|
|    | Hold to enter menu.                          | Press to confirm settings.             |
|    | Press to switch between measurement display. | Press to move up or adjust parameters. |
|   | \  | Press to move down.                    |
|  | \  | Press to return or exit.               |
|  | Only shown in Menu Interface.                | Press to switch between value digit.   |
|  | Only shown in Menu Interface.                | Press to confirm again.                |

### Unlock and Lock

- Lock: The device remains inactive for 30 s and then enters the lock mode.
- Unlock:
  - 1) Press any key to call up unlock prompt.
  - 2) Hold  +  to unlock.
  - 3) Press  to confirm.

## 5.3 Menu

Enter the device menu to select Quick Setup and Advanced Setup.

- Quick Setup: Used to set the main parameters of measurement. Please complete quick setup again when you change the measuring pipe.
- Advanced Setup: Contains all the device parameter settings.

## 6. Configuration

### 6.1 Measurement

Enter the parameters before measurement, including sensor type, pipe parameter, medium parameter, and traverse.

#### 6.1.1 Sensor Type

The transmitter can be compatible with multiple sensors. Please select the corresponding sensor type according to the connected sensor.

The default sensor type of the transmitter is "2", and other types are reserved options. Please refer to the actual device.

#### 6.1.2 Pipe Parameter

Set parameters for measuring pipes, including outer diameter, wall thickness, roughness, and material.

The material of the pipe can be one of the following types: stainless steel, cast iron, PVC and other common types. The sound velocities of transverse and longitudinal waves vary according to different materials of pipes.

The material of the pipe can be entered manually and the corresponding sound velocities of transverse and longitudinal waves can also be entered.

#### 6.1.3 Medium Parameter

Set the fluid attributes in the measuring pipe, including medium type, temperature, and density.

- Medium Type: "Water" is the default. It can be used for measuring flow of drinking water, river water, seawater, groundwater, cooling water, hot water, sewage, and other homogeneous fluids.
- Medium temperature: Supports PT1000 platinum resistance input (connected at the sensor end), 4 to 20 mA current input (refer to "6.2.5 Current Input and Switch Input"), and custom input.

Changes in medium temperature affect the speed of sound in the medium, and accurate input can improve measurement precision.

## 6.1.4 Traverse

The traverse refers to the path that an ultrasonic signal travels through when crossing a pipe once. The number of traverse represents the number of such paths. The device supports 1 to 6 traverses.

Enter the traverse number according to the pipe diameter and sensor mounting type.

- The relationship between different pipe diameters and traverse numbers is shown in the table below.

Table 6-1 Traverse Number and Pipe Diameter Relationship

| Number of Traverses | Pipe Inner Diameter (D, unit: mm) |
|---------------------|-----------------------------------|
| 6 or 5              | D=10                              |
| 4 or 5              | 10<D≤50                           |
| 2 or 3              | 50<D≤300                          |
| 1                   | 300<D≤5000                        |

- For opposite-side sensor mounting, select 1, 3, or 5 traverses; of the pipe; for same-side sensor mounting, select 2, 4, or 6 traverses.



### Caution

When the inner diameter of the pipe is no more than 300 mm, it is recommended to install sensors on the same side and select 2, 4, or 6 traverses; when the inner diameter of the pipe is more than 300 mm, please install sensors on the opposite side and select 1 traverse.

---

## 6.2 Setup

Setup menu is used for setting device signal output and input, low flow cut, damping, etc.

### 6.2.1 Device ID and Unit

- Device ID: The unique identifier of the device. It can be edited only after the device is connected to an external system via Modbus RTU, Bluetooth, etc.
- Unit: For different measurement variables, you can select different measurement units.

## 6.2.2 Totalizer

Totalizer is used to measure the total volume or mass flow of fluid passing through the pipe, and alarm for overflow of accumulated flow.

The device supports three independent totalizers.

Table 6-2 Totalizer Settings Description

| Settings                 | Description   |
|--------------------------|---|
| <b>Process Variable</b>  | Supports measurement of volume flow and mass flow.  |
| <b>Measuring Mode</b>    | Supports flow accumulation in forward or reverse flow direction.<br><b>Net Flow = Forward Flow -   Reverse Flow  .</b>  |
| <b>Overflow</b>          | <ul style="list-style-type: none"> <li>● <b>Hold:</b> The totalizer will stop accumulation when the flow reaches the max. value. The default max. value is INT32_MAX, and the unit is L.</li> <li>● <b>Hold + Alarm:</b> When the flow reaches the max. value, the totalizer will stop accumulation and trigger an alarm. In the status bar in the upper right corner of the device display area, you can see the diagnosis status "S", and in the <b>Diagnosis &gt; Diagnosis Events</b> menu, you can find the specific diagnosis code.</li> <li>● <b>Reset:</b> Clears the accumulated amount when the flow reaches the max. value.</li> </ul> |
| <b>Control Totalizer</b> | Starts or stops totalizer accumulation. Select <b>Reset</b> to clear the accumulated flow of totalizer.   |

## 6.2.3 Output Current

The transmitter adopts the standard 4 to 20 mA signal for current output, which can be connected to systems such as PLC (Programmable Logic Controller) and DCS (Distributed Control System) to achieve real-time monitoring and control of flow.

Table 6-3 Current Output Settings Description

| Settings                | Description  |
|-------------------------|--|
| <b>Process Variable</b> | Supports measurement of volume flow, mass flow, and flow velocity.   |
| <b>Signal Mode</b>      | <ul style="list-style-type: none"> <li>● <b>Active:</b> The signal output is powered by the device's internal power supply .</li> <li>● <b>Passive:</b> The signal output is powered by an external power</li> </ul> |

|                     |  |
|---------------------|--|
|                     | source, such as the input module of PLC.   |
| <b>Range</b>        | Default 4 to 20 mA standard current output (minimum 3.8 mA overrange, maximum 20.5 mA overrange).<br>The flow measurement value corresponding to 4 mA and 20 mA current output can be set separately.  |
| <b>Failure Mode</b> | <ul style="list-style-type: none"> <li>● <b>High/Low Alarm:</b> When the current exceeds the set high/low alarm current, an alarm is triggered and the device enters Fault status. The device outputs alarm current, the screen will display in red, and the “F” diagnosis code will be shown in the display area. The high alarm current supports 21 to 23 mA, and the low alarm current supports 3 to 3.6 mA.</li> <li>● <b>Hold:</b> Keeps outputting the actual current corresponding to the measurement value.</li> </ul> |

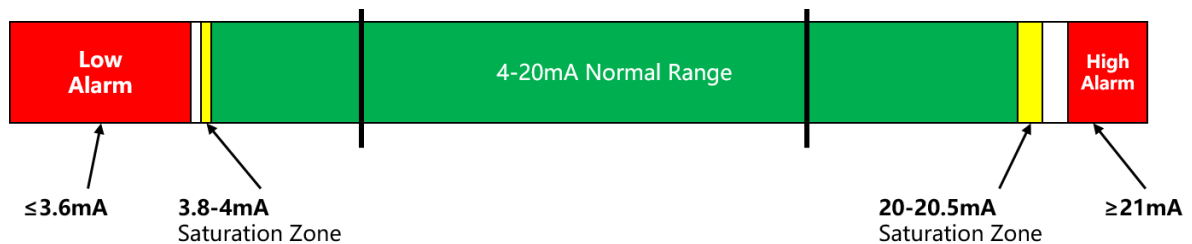

Figure 6-1 4 to 20 mA Current Output

## 6.2.4 PFS Output

PFS represents three different output modes: pulse (P), frequency (F), and switch (S).

### Pulse Output

Measures the flow of the fluid and convert it into a pulse signal output. Each pulse signal usually corresponds to a fixed unit flow, such as 1 m<sup>3</sup> or 1 dm<sup>3</sup>.

Table 6-4 Pulse Output Settings Description

| Settings              | Description   |
|-----------------------|---|
| <b>Pulse Variable</b> | Supports measurement of volume flow, mass flow, and flow velocity.  |
| <b>Pulse Scaling</b>  | The flow rate for each pulse that the device outputs. The pulse scaling unit can be set to unit flow per pulse or pulse per unit flow. For example, if the pulse scaling is 1 dm <sup>3</sup> /pulse and the device |

|                      |  |
|----------------------|--|
|                      | outputs 100 pulses, the accumulated flow is $1000 \times 1 \text{ dm}^3 = 100 \text{ dm}^3$ .            |
| <b>Pulse Width</b>   | The duration of one pulse output signal.   |
| <b>Invert Signal</b> | Converts a high level signal to a low level signal or convert a low level signal to a high level signal. |
| <b>Failure mode</b>  | No signal output when the pulse output is abnormal.  |

### Frequency Output

Converts flow values into frequency signal output for integration with other automation systems or data collection devices.

Table 6-5 Frequency Output Settings Description

| Settings                     | Description   |
|------------------------------|---|
| <b>Freq. Variable</b>        | Supports measurement of volume flow, mass flow, flow velocity.  |
| <b>Max./Min. Frequency</b>   | The range of frequency output, including the maximum and minimum frequency.   |
| <b>Max./Min. Freq. Value</b> | The flow measurement value corresponding to maximum and minimum frequency output.<br>When the flow is below the minimum measurement value, the device outputs <b>Min. Freq. Value</b> ; when the flow is above the maximum measurement value, outputs the <b>Max. Freq. Value</b> . |
| <b>Invert Signal</b>         | Converts a high level signal to a low level signal or convert a low level signal to a high level signal.  |
| <b>Failure mode</b>          | No signal output when the frequency output is abnormal.   |

### Switch Output

Outputs device status signal or alarm signal. Events such as device diagnosis, flow over limit, flow direction check, and low flow cut off support linkage to switch output, indicating the device working status or triggering alarm signals.

Table 6-6 Switch Output Settings Description

| Settings             | Description  |
|----------------------|--|
| <b>Switch Output</b> | 1. <b>Diagnostic Event</b> : Triggers switch output when the device reaches the diagnostic status. |

|                      |  |
|----------------------|--|
|                      | <p>Select different mode:</p> <ul style="list-style-type: none"> <li>● <b>Failure Alarm:</b> The device triggers the switch output when it reaches F status.</li> <li>● <b>Warning:</b> The device triggers the switch output when it reaches S or M status.</li> <li>● <b>Failure/Warning:</b> The device triggers the switch output when it reaches F, S, or M status.</li> </ul> <p>2. <b>Limit:</b> Select the measurement variable (including flow, flow velocity, totalizer, etc.), and set its maximum/minimum value. The device triggers the switch output when the measurement exceeds the limit.</p> <p>Set switch output duration:</p> <ul style="list-style-type: none"> <li>● <b>Switch-on Delay:</b> When the measured value exceeds the maximum, the device outputs a high level signal for the duration of switch-on delay.</li> <li>● <b>Switch-off Delay:</b> When the measured value is below the minimum, the device outputs a low level signal for the duration of switch-off delay.</li> </ul> <p>3. <b>Flow Check:</b> Select <b>Enable(Forward)</b> in <b>Status</b> to set the pipe flow as forward flow, and the device will trigger the switch output when the pipe generates a reverse flow.</p> <p>4. <b>Status:</b> Select <b>Low Flow Cut Off</b> in <b>Status</b> to trigger the switch output when a low flow cut off is performed.</p> |
| <b>Invert Signal</b> | Converts a high level signal to a low level signal or convert a low level signal to a high level signal.   |
| <b>Failure mode</b>  | <p>For <b>Diagnostic Event</b>, refer to the above description for failure mode.</p> <p>For <b>Limit, Flow Check, and Status</b>, when failure mode is enabled, no signal will be output when the switch output is abnormal.</p>   |

### 6.2.5 Current Input and Switch Input

Changes in fluid such as temperature and density can affect the sound velocity. You can input real-time value from external sensors (e.g., temperature sensor) via current input. Thus, the device can correct the sound velocity accordingly to improve measurement precision.

The switch input can be used to input triggering signals from external systems (e.g., PLC) to device to achieve function control such as totalizer reset.

Table 6-7 Input Settings Description

| Settings             | Description   |
|----------------------|---|
| <b>Current Input</b> | <ol style="list-style-type: none"> <li>1. In <b>Input Parameter</b>, select the parameter type.</li> <li>2. Set <b>Upper Range</b> and <b>Lower Range</b> of the input.</li> </ol>  |
| <b>Switch Input</b>  | <ol style="list-style-type: none"> <li>1. In <b>Switch Input</b>, select the function control type.</li> <li>2. Select <b>Trigger Level</b> of input signal as <b>High</b> or <b>Low</b>.</li> <li>3. Set <b>Response Time</b>. The device delays the function control (e.g., totalizer reset) from the switch input signal until after the response time has passed to avoid false trigger.</li> </ol> |

 **Note**

If the source of the medium temperature is **4 to 20 mA Input**, you also need to set the current input parameter as **Temperature**, as to keep the current input variable consistent.

### 6.2.6 Low Flow Cut Off

When the measured flow is lower than the preset value, it will be regarded as an invalid signal and set to zero output. The function can cut off small flow fluctuation caused by noise, pipe vibration, etc., to improve the authenticity of flow measurement.

Table 6-8 Low Flow Cut Off Settings Description

| Settings                 | Description  |
|--------------------------|--|
| <b>Process Variable</b>  | Supports cut of volume flow, mass flow, and flow velocity.   |
| <b>On Value</b>          | Low flow cut off is enabled when the flow value is below the <b>On Value</b> , and the value will be set to "0" until the flow value is higher than the <b>Off Value</b> .   |
| <b>Off Value</b>         | Low flow cut off is turned off when the flow value is higher than the <b>Off Value</b> and the actual flow value will be output.   |
| <b>Surge Suppression</b> | The duration of the low flow cut off. The flow value remains "0" within this period after the low flow cut off is enabled. The device will wait for the end of this period to determine whether to turn off the low flow cut off according to the actual flow value. |

### **Caution**

If the on value is too high, the actual low flow may be cut off by mistake. Adjust the value according to the actual situation.

---

### **Note**

When the low flow cut off is triggered, the device will not output pulse or totalize flow.

## 6.2.7 Measuring Mode

The device supports two measurement principles for flow velocity: the time difference method and the Doppler effect method, please refer to "1.3 Basics".

You can select three measuring modes: time difference, Doppler effect, or auto-switch.

- **Time Difference:** Applicable to the measurement of fluid with no or few bubbles and solids.
- **Doppler Effect:** Applicable to the measurement of fluid with a certain percentage of bubbles/solids.
- **Auto-Switch:** Automatically switches between time difference and Doppler effect based on the fluid conditions.

## 6.2.8 Damping

Damping refers to the time required for the output signal to stably transition from an initial state to a new state when the fluid flow velocity changes. It is used to smooth out the transient signal fluctuations caused by fluid disturbances and other factors, avoiding frequent numerical fluctuations and improving measurement stability.

### ● **Damping Time**

The damping time is usually set to 1 to 10 seconds. Please adjust it according to the fluid characteristics, pipe conditions, etc., to balance the response speed and measurement stability.

### **Note**

- The longer the damping time is, the smaller fluctuation of measurement will be. However, if it is too long, the device response may be delayed and the real-time flow changes may not be reflected.
- The shorter the damping time is, the faster the device can respond to fluid changes. However, if it is too short, it may cause signal fluctuation and affect the measurement stability.

## 6.2.9 Write Protection

Set the administrator password to add devices with access permission, so that non-administrator users cannot edit device data.

- **Activate/Deactivate:** Password required first, default "0000".
- **Auto-Activate:** When the auto-activate time is reached, the device will enter locked protection status and you need to enter the password to unlock it.
- **Change Password:** Supports changing the write protection password. Enter the old password first to set a new one.

### Note

The write protection lock only takes effect for device-side access. Client and App via communication protocols such as Modbus can still access the device and write data.

## 6.3 Display

Adjust the display style of measurement values in display area, set system language, contrast, and brightness, etc.

Table 6-9 Display Settings Description

| Settings                | Description  |
|-------------------------|--|
| <b>Language</b>         | Default: Chinese.  |
| <b>Display Format</b>   | Refer to "6.3.1 Display Format" for the format of measurement information in display area.   |
| <b>Decimal Places</b>   | The display area will cyclically show 4 measurement values, and you can set the decimal points for different measurement values.   |
| <b>Variable Display</b> | The display area will cyclically show 4 measurement values, and you can set the variable type for different measurement values.  |
| <b>Backlight</b>        | If you enable this, the screen background will display green or red light.<br>Green light is displayed by default. The screen will turn red to alarm when F diagnosis status occurs. |
| <b>Contrast</b>         | The color contrast of the device screen.<br>The higher the contrast is, the stronger the color and the clearer the visual effect will be.  |

### 6.3.1 Display Format

The device supports three display formats, each with different measurement values displayed.

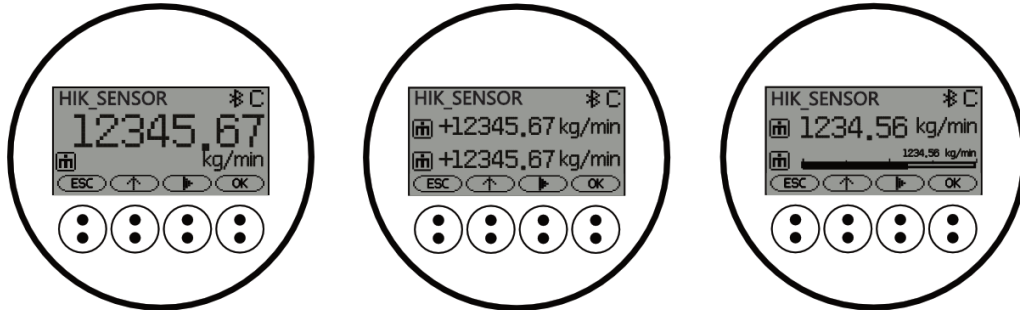

Figure 6-2 Three Display Formats

- **1 Value:** In the display area, each time, only one measurement variable will be displayed in the maximum font size.
- **2 Values:** In the display area, two measurement variables will be displayed simultaneously.
- **1Value+1Bar graph:** In the display area, one measurement variable value is displayed, and the value is presented as a percentage of the range of the bar graph.

You can customize the range of the bar graph, including the value corresponding to 0% and that to 100%.

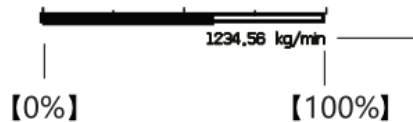

Figure 6-3 Bar Graph Description

### 6.4 Diagnosis

The diagnosis function is used for regular self-checks and troubleshooting of device status. You can view the operating time of device, check the diagnosis status, and perform simulation for output verification.

Table 6-10 Diagnosis Settings Description

| Settings              | Description   |
|-----------------------|---|
| <b>Total Time</b>     | The total operating time of device since the first startup. |
| <b>Operating Time</b> | The operating time of device since last startup.            |

|                         |   |
|-------------------------|---|
| <b>Diagnosis Status</b> | Switch to view device exception information. Refer to "6.4.1 Diagnosis Status".       |
| <b>Simulation</b>       | Test the signal output status by using simulation value. Refer to "6.4.2 Simulation". |

### 6.4.1 Diagnosis Status

The device support self-diagnosis function, guaranteeing real-time acquisition of whether the basic functions of device are normal during measurement. In the diagnosis status menu, you can view specific diagnostic information, including diagnosis status (C, F, M, S) and code (e.g. F017).

Table 6-11 Diagnosis Status Description

| Status | Category               | Description   |
|--------|------------------------|---|
| C      | Function Check         | The device is performing a function check or test. The measurement value is temporarily invalid.  |
| F      | Fault                  | Device function fault exists.   |
| M      | Maintenance Required   | The current measurement value is valid, but the device is affected by external factors and its functions and performance are limited.<br>A fault may occur in the short term, and maintenance is required. For example, sensor probe temperature is too high. |
| S      | Specification Exceeded | The measurement value is uncertain and device specifications is exceeded, such as excessive temperature of electronic components.   |

 **Note**

When the device is in F diagnosis status, the screen background will turn to red (**Backlight** function enabled), the diagnosis status in the upper-right corner of the display area will show "F", and intermittent pop-up window will show the diagnosis status and code, as shown in the following figure.

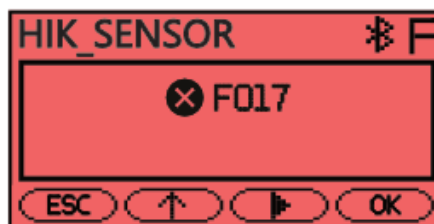

Figure 6-4 F Diagnosis Status

## 6.4.2 Simulation

Enter the simulated value to simulate the actual signal output of the device, which can be used for performance testing and troubleshooting of measurement value, current/frequency/pulse, and alarm output.

Three simulation modes are supported: **Measured Value** simulation, **Output** simulation, and **Alarm** simulation.

## 6.5 Additional Settings

Additional settings are used to set the device's time, communication parameters such as Modbus and Bluetooth, and can also be used to restore to factory settings.

### 6.5.1 Date and Time

Device provides RTC (Real-Time Clock) time and can normally record time within 90 days during power outages. It supports manual verification of date and time.

### 6.5.2 Integration and Communication

Table 6-12 Communication Settings Description

| Settings          | Description  |
|-------------------|--|
| <b>Modbus RTU</b> | Connect to the client via Modbus protocol for data communication. See details below. |
| <b>Bluetooth</b>  | Connect to the App via Bluetooth for data communication. See details below.          |

### Modbus RTU

The device adopts the RS-485 interface to access the Modbus RTU protocol for communication, which can realize data transmission between device and client or other industrial devices.

Using the client, you can configure device parameters, upgrade firmware, export historical data and logs, download diagnosis information, etc., to meet the needs of production commissioning.

1. Connect the RS-485 terminal of the device to the USB/RS-485 converter and then connect the USB cable to a computer via USB interface.

 **Note**

You need to purchase the converter separately. When wiring RS-485, make sure that A line is connected to A pin and B line is connected to B pin.

2. Connect the power supply to power on the flow meter and set its communication address and RS-485 parameters.

Table 6-13 Modbus Settings Description

| Settings                  | Description  |
|---------------------------|--|
| <b>Modbus-RTU address</b> | The unique Modbus address of the device, 1~255, in decimal.            |
| <b>Baud Rate</b>          | Default: 9600.   |
| <b>Data Bit</b>           | Default: 8.  |
| <b>Stop Bit</b>           | Default: 1.  |
| <b>Parity Bit</b>         | Default: Even Parity. None, Odd Parity, and Even Parity are supported. |

3. Start the client on the computer, set communication parameters, and search for and add the device.

---

 **Caution**

The RS-485 parameters of the device and the client should be consistent, or the client cannot search for and add the device.

---

4. After adding the device to the client, you can view the device status and measurement data and configure the device via the client.

## Bluetooth

The Bluetooth function enables the device to communicate with the App on the mobile device (e.g. smartphone). Using the App, you can remotely and conveniently configure the device function, monitor data, and perform other operations.

1. Set the Bluetooth status of device to “Yes”.

 **Note**

- Enter the password to activate and use the Bluetooth function for the first time.
  - Please save your Bluetooth password.
2. Start the App on smartphone, place the smartphone close to the device, and search for and add the device.

3. After adding the device to the App, you can view the device status and measurement data and configure the device via the App.

### 6.5.3 Storage and Reset

Table 6-14 Storage and Reset Settings Description

| Settings       | Description   |
|----------------|---|
| <b>Storage</b> | Check the remaining storage space of devices. When the storage space is full, you can overwrite or not save new data.   |
| <b>Reset</b>   | <p>Basic Reset: Restore parameters except for communication protocol (Modbus, Bluetooth, etc.) parameters to prevent communication exceptions.</p> <p>All Reset: Clear all user data and restore the device to the factory settings. Historical data and measurement accumulations will not be cleared.</p> |

## 6.6 Calibration

The device may produce measurement deviation due to the sensor characteristics, changes in medium temperature, and pipe vibration after long-term operation. By using the specific calibration function, these measurement deviations can be eliminated to improve measurement accuracy.

Table 6-15 Calibration Settings Description

| Settings               | Function   | Configuration   |
|------------------------|--|---|
| <b>Zero Setting</b>    | When the pipe is full of liquid and static, the function can be used to calibrate the measurement deviation as zero so that the device outputs zero value when there is no flow. | Select "Zero Setting" to automatically calibrate the zero point when the fluid in the pipe is static and full.  |
| <b>Multiple Calib.</b> | Enter the standard flow velocity and actual flow velocity for up to 20 points to calibrate the flow measurement for on-site conditions.  | <ol style="list-style-type: none"> <li>1. Set the number of calibration points.</li> <li>2. Set the nominal value and actual value for each calibration point.</li> <li>3. After setting all calibration points, perform multiple calibration.</li> </ol> |

 **Caution**

- Make sure the liquid in the pipe is still and there is no strong magnetic field interference or violent vibration around it when you perform zero calibration.
- Temperature changes may affect zero calibration. It is recommended to re-calibrate the zero point under different temperature conditions.

## 6.7 Sensor

Control the sensor's position to improve signal quality, and ensure measurement accuracy and stability.

Table 6-16 Sensor Settings Description

| Settings               | Function   | Configuration  |
|------------------------|--|--|
| <b>Signal SNR</b>      | The <b>Signal</b> is the intensity of the ultrasonic wave received by the sensor. The larger the <b>Signal</b> , the higher the <b>SNR</b> , and the more stable the measurement result. | If the <b>SNR</b> is higher than 24%, it means that the signal quality meets the requirements. If the <b>SNR</b> is lower than 24%, it means that the signal quality is poor and you need to adjust the installation spacing of sensor, check the coupling agent, check the pipe condition, or adjust the medium temperature parameter, etc.<br><br>In actual use, the SNR should be stable above 60% to ensure the detection stability. |
| <b>Sensor Position</b> | <b>TU</b> is the upstream sensor probe and <b>TD</b> is the downstream sensor probe. Normally, <b>TU</b> should be installed in the upstream of the pipe.                                | When the flow direction is opposite to the sensor installation direction or the signal cable is connected reversely, you can set "TU (Down) " so that the device automatically inverts the signal to ensure that the measurement value is consistent with the actual flow direction.   |
| <b>Sensor Check</b>    | Test the sensor's working status. It can be used to check the whole measurement system when an exception occurs in measurement.  | Apply the sensor transmissive surfaces with coupling agent, place them together with surfaces in close contact, and perform testing.   |

## 6.8 About

View device ID, factory No., device model, version, manufacturer and variable value, etc.

## 7. Diagnosis Code

| Diagnosis Status | Diagnosis Code | Description   |
|------------------|----------------|---|
| S                | 208            | PCB Temperature Exceeded Limit                      |
| S                | 003            | IO Temperature Exceeded Limit                       |
| S                | 811            | Medium Temperature Exceeded Limit                   |
| F                | 006            | Medium Temperature Sensor Exception                 |
| F                | 815            | Voltage Abnormal                                    |
| S                | 814            | Current Input Exceeded Limit                        |
| S                | 808            | Current Exceeded Limit                              |
| S                | 809            | Pulse Exceeded Limit                                |
| S                | 810            | Frequency Exceeded Limit                            |
| S                | 812            | Flow Exceeded Limit                                 |
| S                | 813            | Totalizer Overflow Exceeded Limit                   |
| F                | 205            | Storage Chip Exception                              |
| F                | 203            | PCB Key Component Exception                         |
| F                | 004            | Sensor Exception                                    |
| F                | 206            | Real-Time Clock Exception                           |
| F                | 207            | Platform Communication Exception                    |
| F                | 200            | Bluetooth Communication Error                       |
| F                | 201            | Screen Communication Exception                      |
| F                | 007            | Exception Occurred When Collecting Data From Sensor |
| F                | 405            | Parameter Settings Exception                        |
| C                | 400            | In Simulation Mode                                  |

## 8. Troubleshooting

If any issue occurs when operating the device, please check the device from the following directions.

If the issue still cannot be solved, please contact our technical support.

Table 8-1 Troubleshooting

| Issue                                       | Possible Causes  | Solution   |
|---|--|--|
| <b>No signal is received by flow meter.</b> | Foreign object on sensor surface.                                | Check and clean the sensor surface.  |
|   | Incorrect sensor installation position.                          | Adjust the sensor installation position. Refer to "4.1.1 Select Installation Position" for details.  |
|   | Insufficient or unevenly applied coupling agent.                 | Apply coupling agent on the sensor again.  |
|   | Pipe aging, corrosion, and swell, with poor pipe wall condition. | Grind the pipe wall or adjust the installation position.   |
|   | Incorrect measuring mode.  | The two methods are applicable to different conditions. It is recommended that you switch the mode and check whether the signal-to-noise ratio meets the requirement, or use <b>Auto-Switch</b> mode. Refer to "6.2.7 Measuring Mode".                                   |
|   | The medium does not meet the measurement conditions.             | <ol style="list-style-type: none"> <li>1. Not full pipe.</li> <li>2. Too many bubbles in the medium, or too much solid particles, or flocculent latex-like substance, which causes poor homogeneity of the medium and cannot meet the measurement conditions.</li> </ol> |

## Clamp-on Ultrasonic Flow Meter • User Manual

| Issue   | Possible Causes  | Solution   |
|---|--|--|
| <b>The signal strength of the flow meter is unstable, and the value deviates significantly from the actual flow, or fluctuates obviously.</b> | The distance between the device and the straight pipe section or flow disturbance source (such as pump, valve, T-joint, double bend pipe, etc.) is insufficient. | Adjust the installation position. Refer to "4.1.1 Select Installation Position" for details.   |
|   | Severe fluctuation of the medium status.   | The impurity content of the medium changes significantly over time and the condition is not applicable. It is recommended to increase the damping time to improve stability. |
|   | The temperature change causes the sound velocity to change.  | Enter the accurate medium temperature, or use an external temperature sensor for temperature compensation.   |
|   | Strong electromagnetic interference exists near the device.  | Keep the device away from the interference source.   |
|   | The sensor is installed in the vibration area of the pipe.   | Install the sensor away from the vibration source., or enable the Low Flow Cut Off function to remove interference.  |
| <b>Show non-zero value when no flow.</b>  | The sensor is installed in the vibration area of the pipe.   | Install the sensor away from the vibration source., or enable <b>Low Flow Cut Off</b> function to remove interference.   |
|   | Strong electromagnetic interference exists near the device.  | Keep the device away from the interference source.   |
| <b>Flow meter signal strength gradually decreases.</b>  | The surface of the sensor is scaling.  | Clean the sensor surface.  |
|   | The sensor accumulates particles or the sensor is aging.   | Clean the sensor and calibrate the device regularly.   |
|   | Coupling agent aging.  | Apply the coupling agent again.  |

| Issue   | Possible Causes   | Solution   |
|---|---|--|
|   | Insufficient tightening of the holder. It may be loose. | Tighten the holder again.  |
| <b>Flow meter stops measuring in running.</b> | The measured medium changes.                            | Check the signal-to-noise ratio to see if the medium meets the measurement requirements. |
|   | Device fault.   | Please contact our technical support.  |

## 9. Regulatory Information

### Note

These clauses apply only to the products bearing the corresponding mark or information.

### EU Conformity Statement



This product and - if applicable - the supplied accessories too are marked with "CE" and comply therefore with the applicable harmonized European standards listed under the Directive 2014/30/EU (EMCD) and Directive 2011/65/EU (RoHS).

Note: The products with the input voltage of within 50 to 1000 VAC or 75 to 1500 VDC comply with Directive 2014/35/EU (LVD), and the rest products comply with Directive 2001/95/EC (GPSD). Please check the specific power supply information for reference.

Warning: This is a class A product. In a domestic environment this product may cause radio interference in which case the user may be required to take adequate measures.



Directive 2012/19/EU (WEEE Directive): Products marked with this symbol cannot be disposed of as unsorted municipal waste in the European Union. For proper recycling, return this product to your local supplier upon the purchase of equivalent new equipment, or dispose of it at designated collection points. For more information see: [www.recyclethis.info](http://www.recyclethis.info)



Regulation (EU) 2023/1542 (Battery Regulation): This product contains a battery and it is in conformity with the Regulation (EU) 2023/1542. The battery cannot be disposed of as unsorted municipal waste in the European Union. See the product documentation for specific battery information. The battery is marked with this symbol, which may include lettering to indicate cadmium (Cd), or lead (Pb). For proper recycling, return the battery to your supplier or to a designated collection point. For more information see: [www.recyclethis.info](http://www.recyclethis.info).

## 10. Modbus Communication Protocol

Scan the QR code to get the Modbus communication protocol address of device service and function command.

 **Note**

The function varies according to different device models. Please take the actual device for reference.





**HIKMICRO**

See the World in a New Way